

FRONT VIEW

THIS DOCUMENT IS FOR THE SOLE USE OF INDIVIDUALS AND IS NOT INTENDED TO BE COPIED OR DISTRIBUTED WITHOUT PERMISSION FROM SPIRAL ARTS, INC.

975 DAY TANK	SPIRAL ARTS		
	975 Day Tank Corral Frame		
LICENSED TO: PUBLIC DOMAIN	SCALE 1:10	Date 9/13/2005	
File: Coral Frame.dft		Copyright Spiral Arts 2002	Drawn by Fred Metz

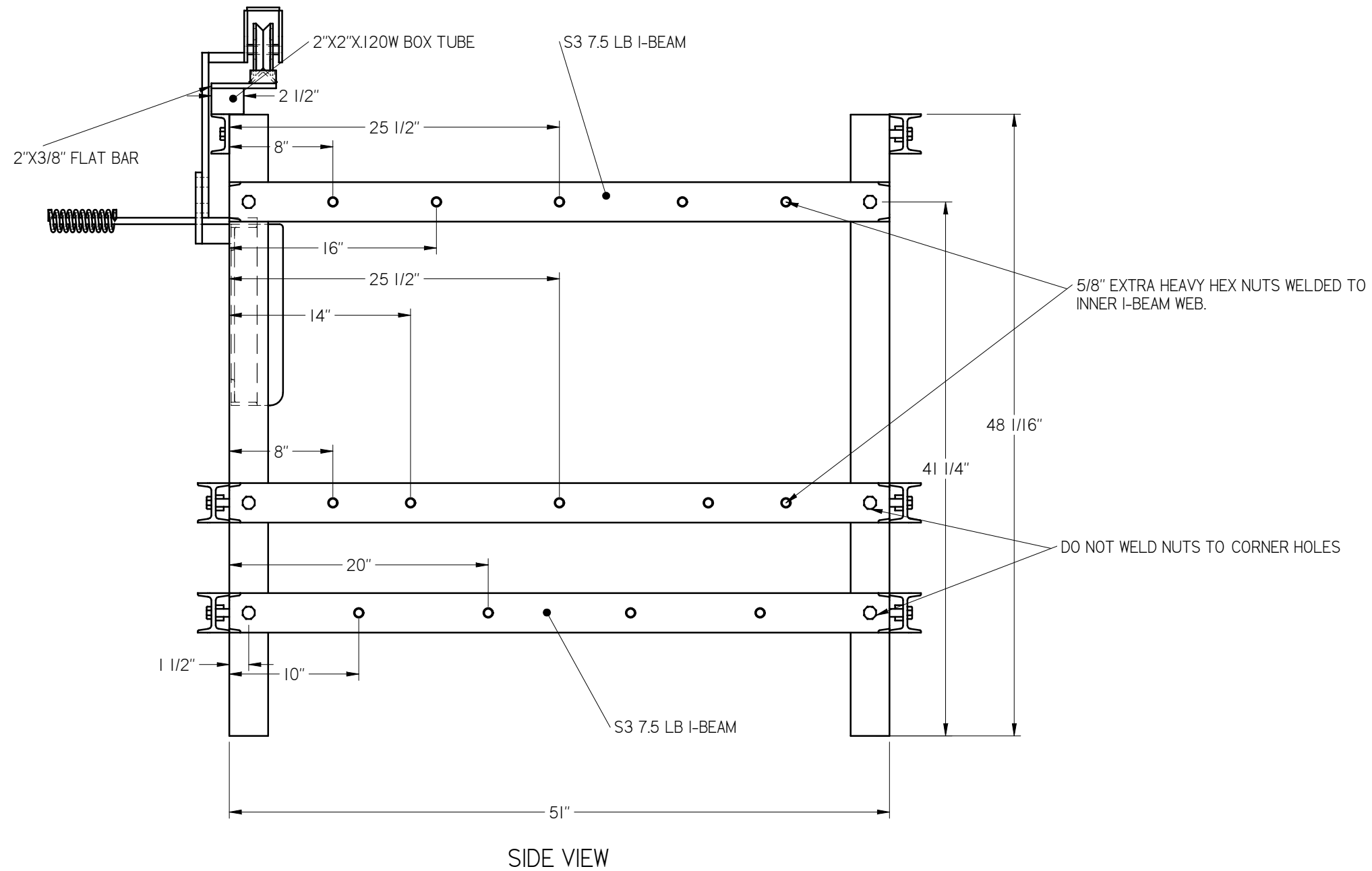

THIS DOCUMENT IS FOR THE SOLE USE OF INDIVIDUALS AND IS NOT INTENDED TO BE COPIED OR DISTRIBUTED WITHOUT PERMISSION FROM SPIRAL ARTS, INC.

975 DAY TANK	SPIRAL ARTS		
	975 Day Tank Corral Frame		
LICENSED TO: PUBLIC DOMAIN	SCALE 1:10	Date 9/13/2005	
File: Coral Frame.dft		Copyright Spiral Arts 2002	Drawn by Fred Metz

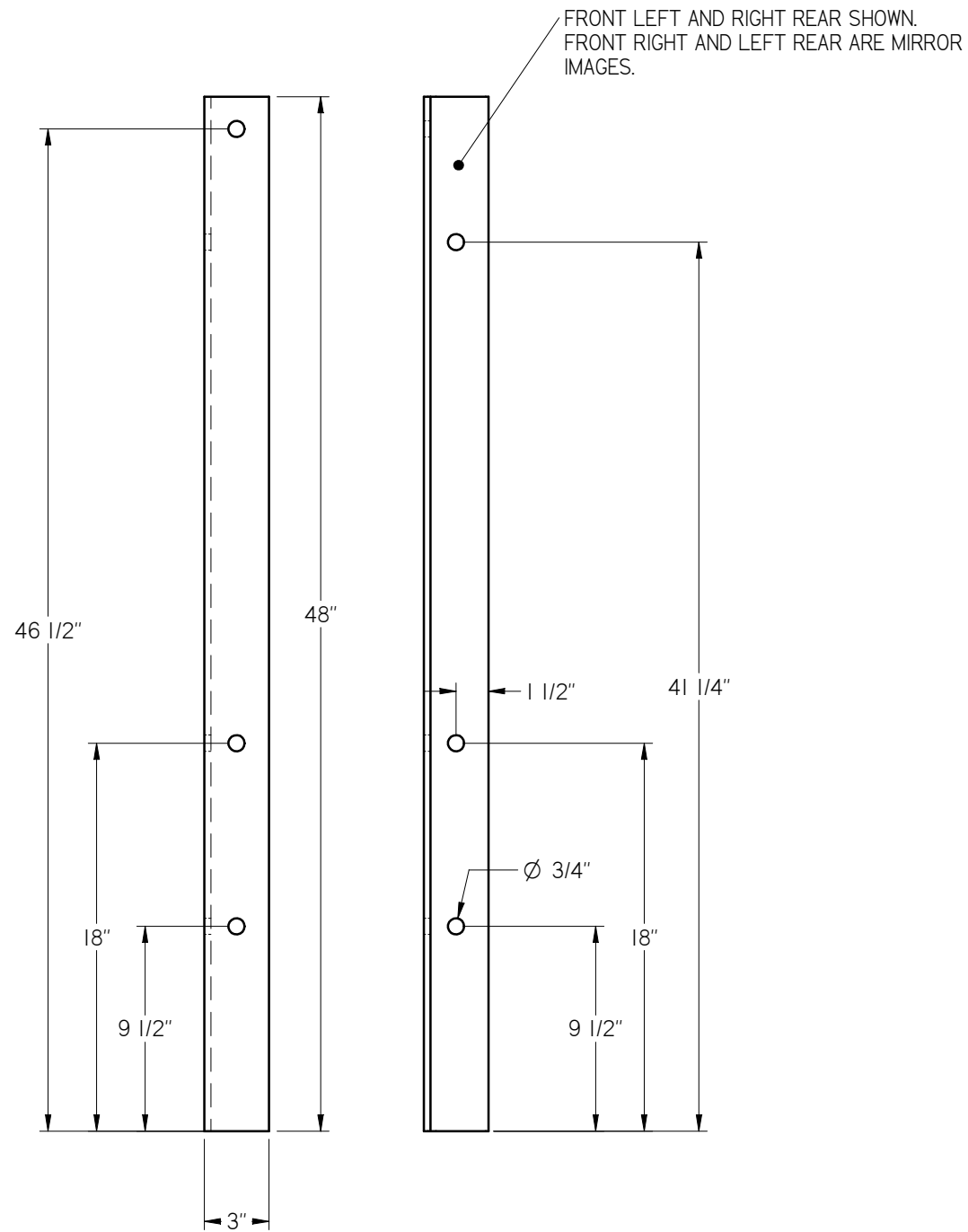

3X3X5/16 ANGLE

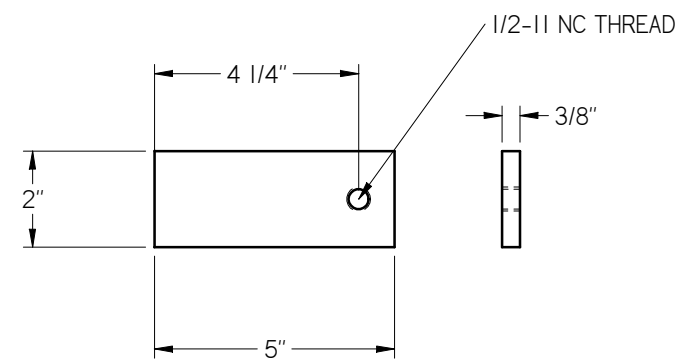
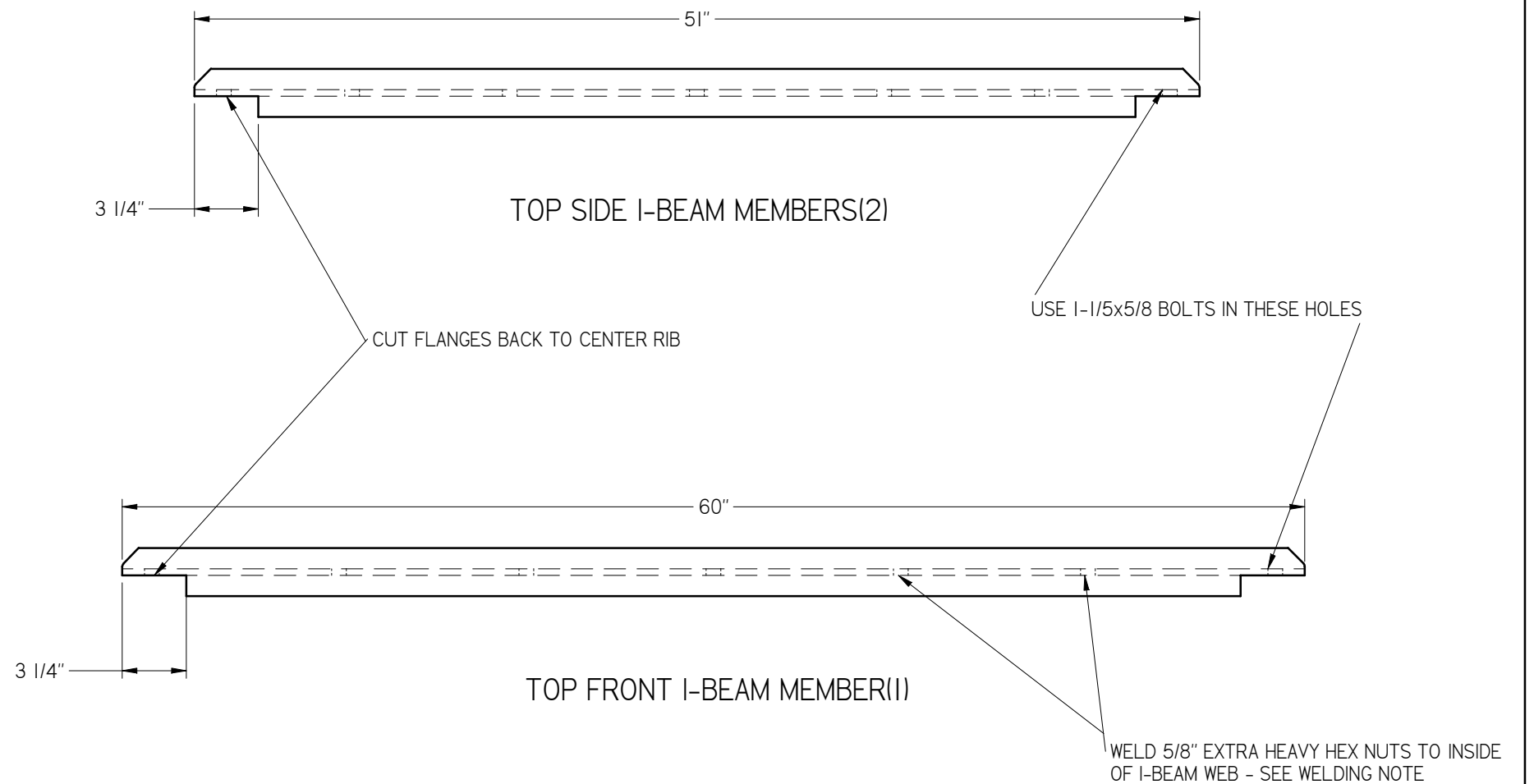

DOOR RAIL TAB(2) WITH HOLES

THIS DOCUMENT IS FOR THE SOLE USE OF INDIVIDUALS AND IS NOT INTENDED TO BE COPIED OR DISTRIBUTED WITHOUT PERMISSION FROM SPIRAL ARTS, INC.

975 DAY TANK	SPIRAL ARTS		
	975 Day Tank Corral Frame		
LICENSED TO: PUBLIC DOMAIN	SCALE 1:10	Date 9/13/2005	
File: Coral Frame.dft		Copyright Spiral Arts 2002	Drawn by Fred Metz

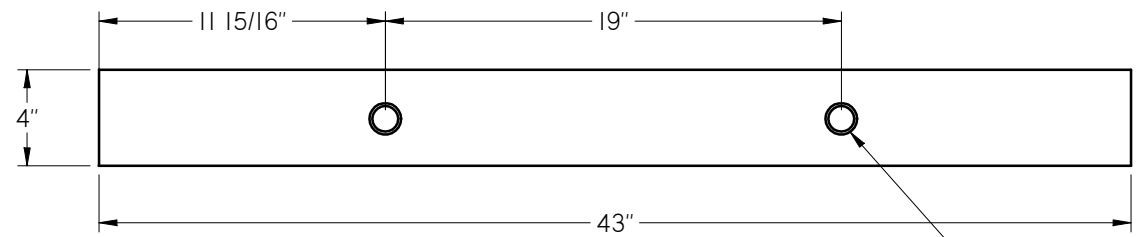

Arch push plates (2)

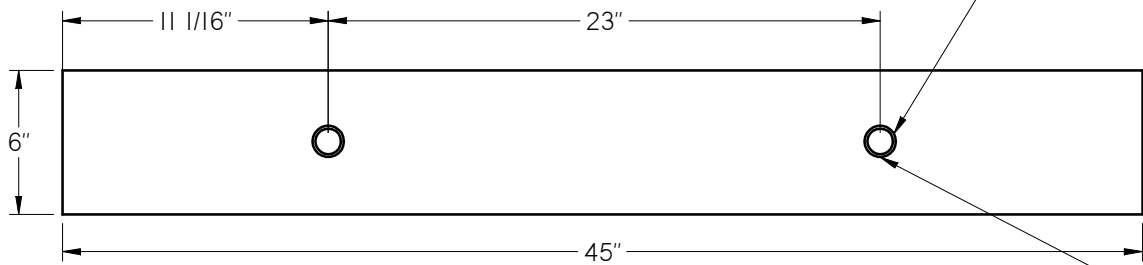

Middle Sides (2)

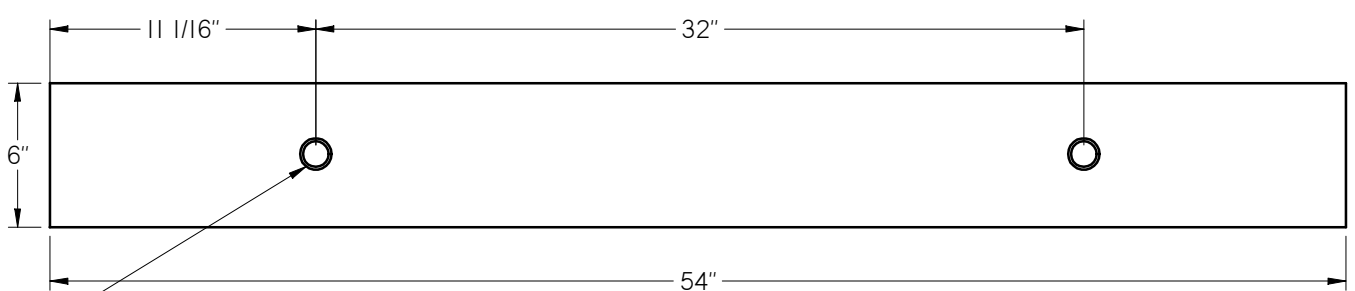

Middle Front & Back (2)

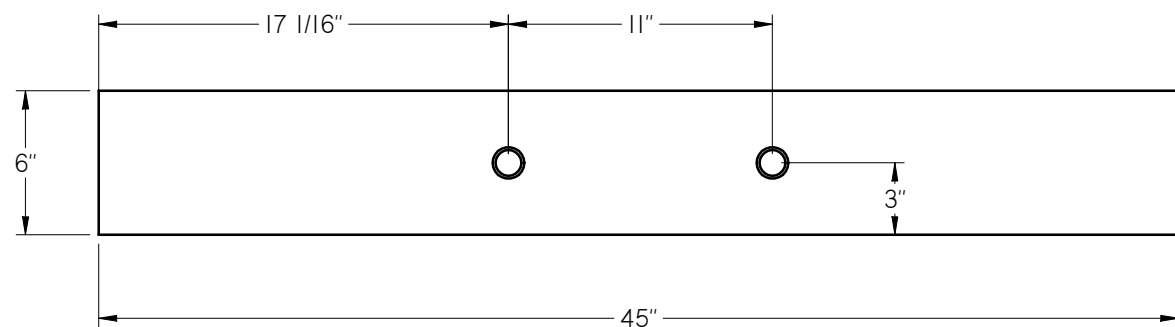

Lower Sides (2)

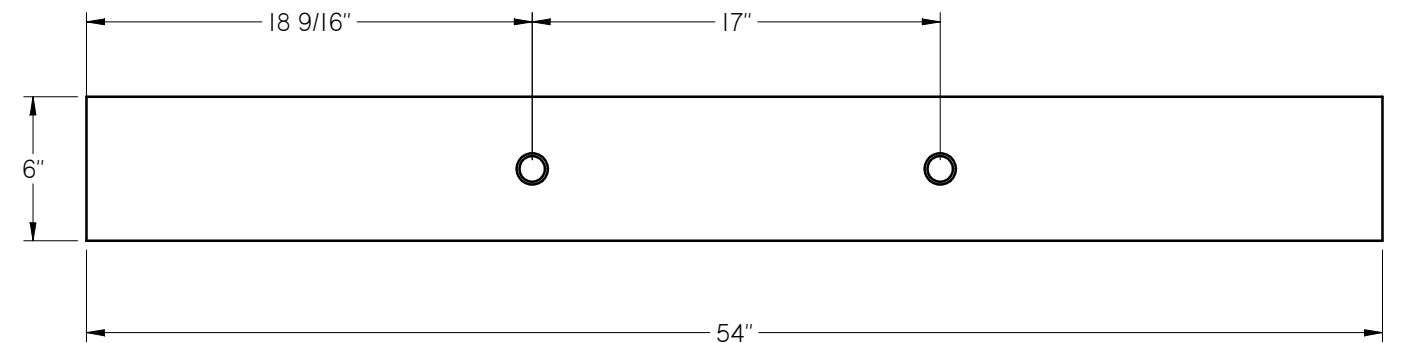

Lower Front & Back (2)

RETENTION RING - 1" PIPE x 3/8" LONG

ATTACH ALL RINGS WITH ONLY THREE SMALL TACK WELDS!

ALL PUSH PLATES ARE 1/4" THICK FLAT BAR

THIS DOCUMENT IS FOR THE SOLE USE OF INDIVIDUALS AND IS NOT INTENDED TO BE COPIED OR DISTRIBUTED WITHOUT PERMISSION FROM SPIRAL ARTS, INC.

975 DAY TANK	SPIRAL ARTS		
	975 Day Tank Corral Frame		
LICENSED TO: PUBLIC DOMAIN	SCALE 1:8	Date 9/13/2005	
File: Coral Frame.dft		Copyright Spiral Arts 2002	Drawn by Fred Metz