

NOTE: BUILD TRAY WITH FIRST LAYER OF BRICKS, ASSEMBLE FLUE BRICKS, THEN BUILD FRAME STEEL AROUND BRICK WORK. CLAMPING STEEL TO BRICK WORK CREATES TIGHT FIT BETWEEN STEEL AND BRICKS.

THIS DOCUMENT IS FOR THE SOLE USE OF INDIVIDUALS AND IS NOT INTENDED TO BE COPIED OR DISTRIBUTED WITHOUT PERMISSION FROM SPIRAL ARTS, INC.

<b>975 DAY TANK</b>	<b><i>SPIRAL ARTS</i></b>		
	<b>FLUE ASSEMBLY</b>		
LICENSED TO: PUBLIC DOMAIN		<b>FRED METZ 9/13/04</b>	
	<small>Copyright Spiral Ars 2002</small>		

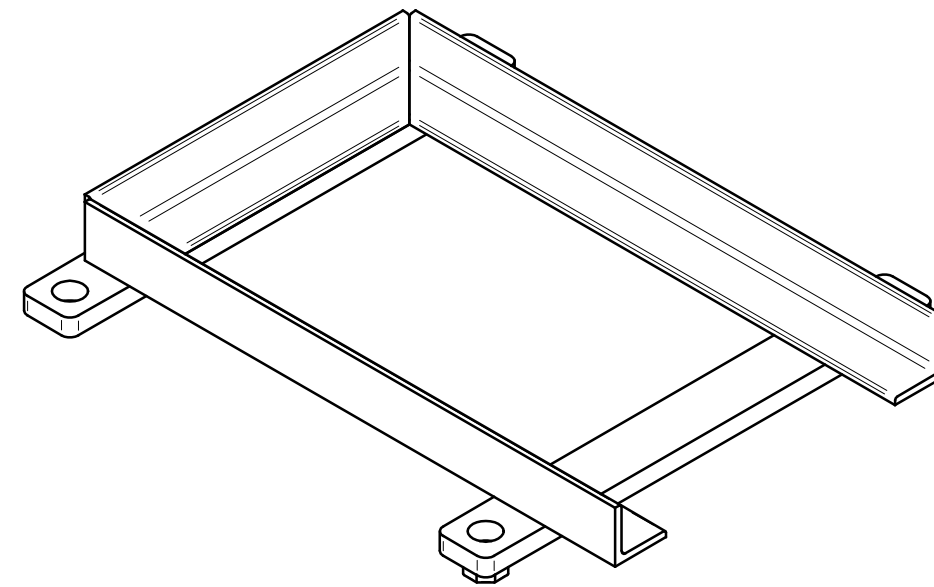
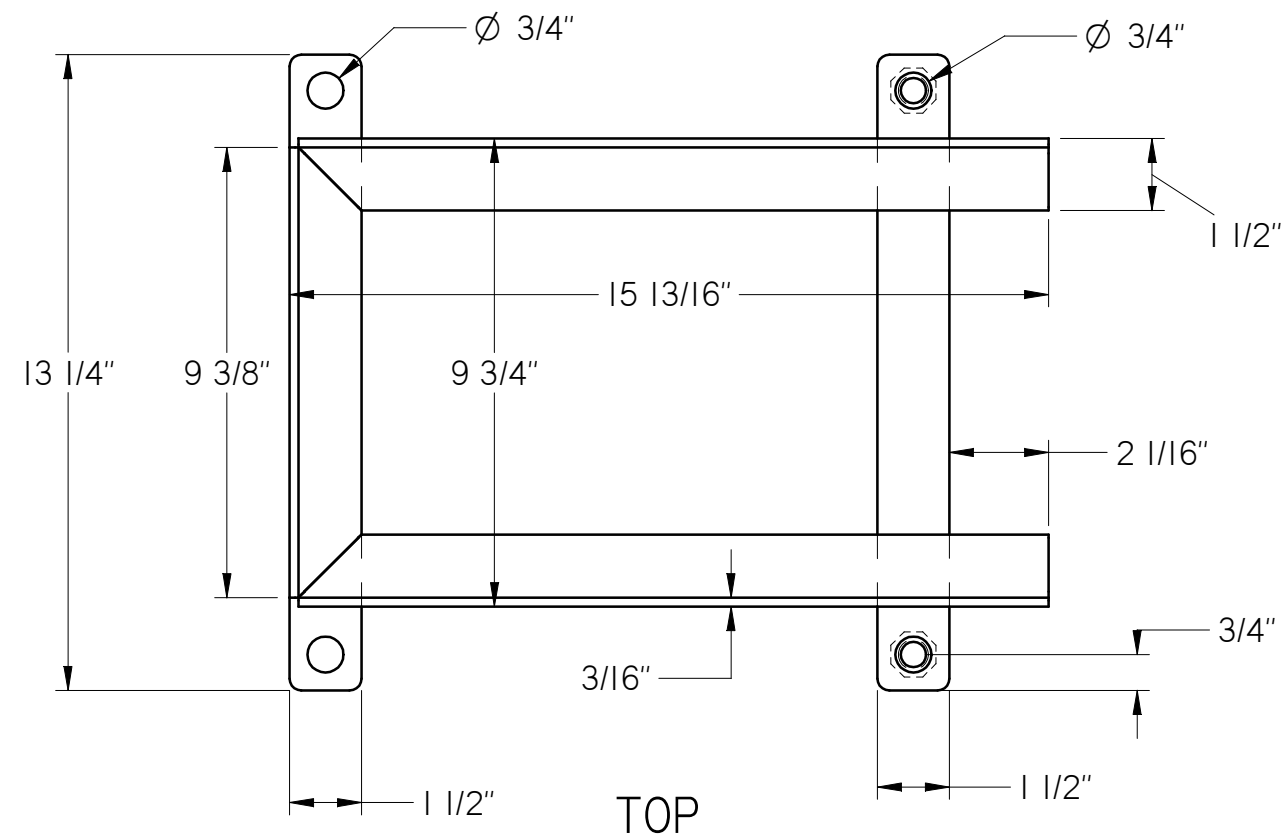

FLUE FRAME TRAY

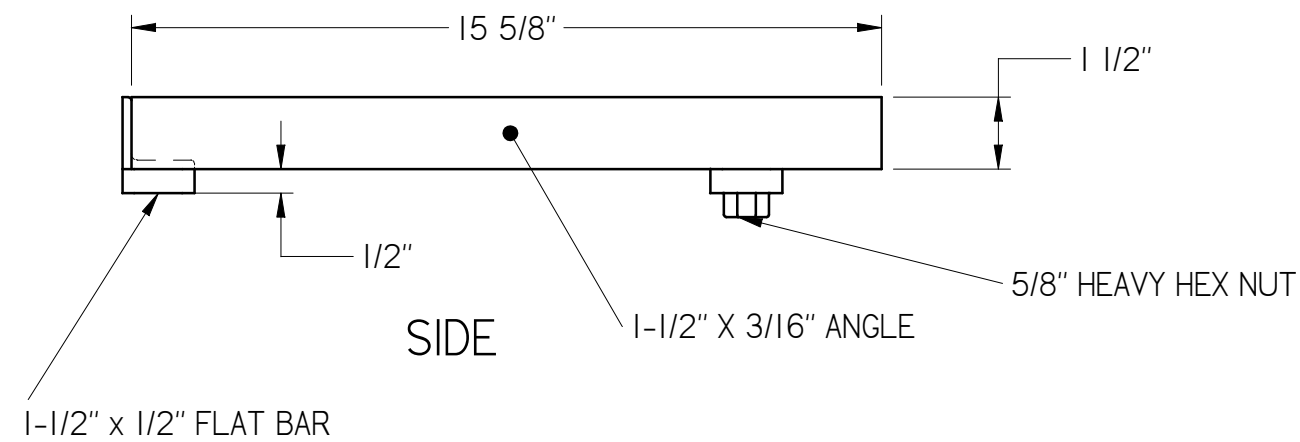

NOTE: WHEN BUILDING TRAY, BEFORE WELDING, INSTALL FIRST LAYER OF FLUE BRICKS, THEN CLAMP AND WELD TRAY ANGLE IRON TO CREATE TIGHT FIT BETWEEN BRICKS AND STEEL

THIS DOCUMENT IS FOR THE SOLE USE OF INDIVIDUALS AND IS NOT INTENDED TO BE COPIED OR DISTRIBUTED WITHOUT PERMISSION FROM SPIRAL ARTS, INC.

<b>975 DAY TANK</b>	<b>SPIRAL ARTS</b>		
	<b>FLUE FRAME TRAY</b>		
LICENSED TO: PUBLIC DOMAIN		<b>FRED METZ 9/13/04</b>	
	<small>Copyright Spiral Ars 2002</small>		

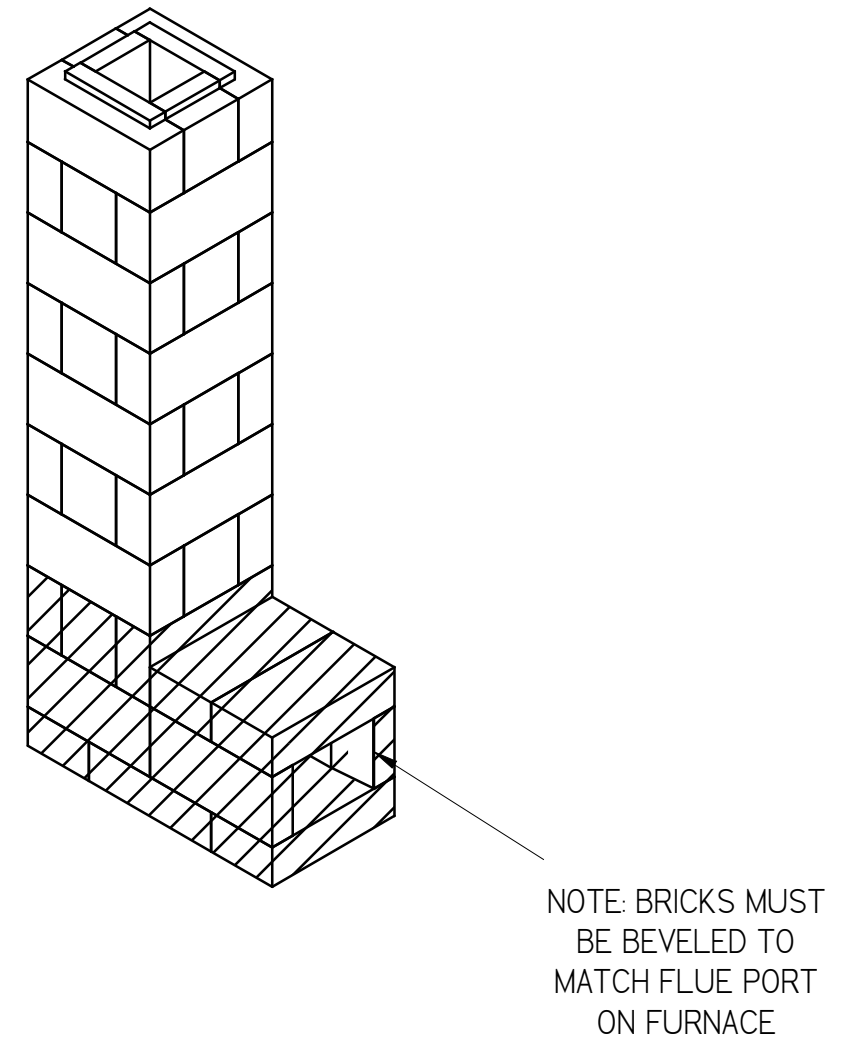
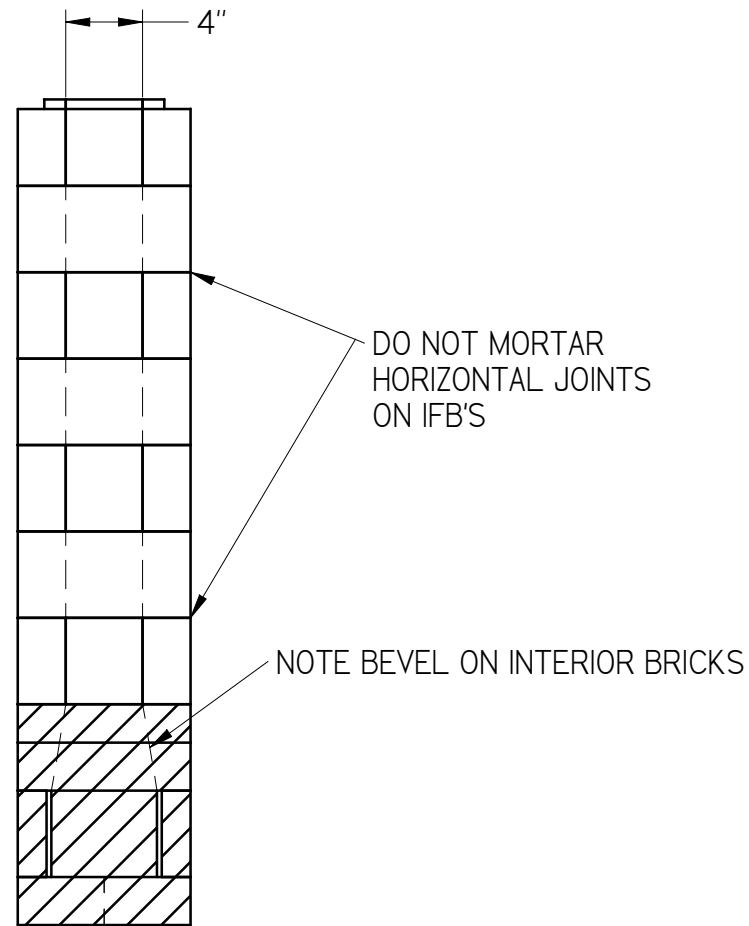
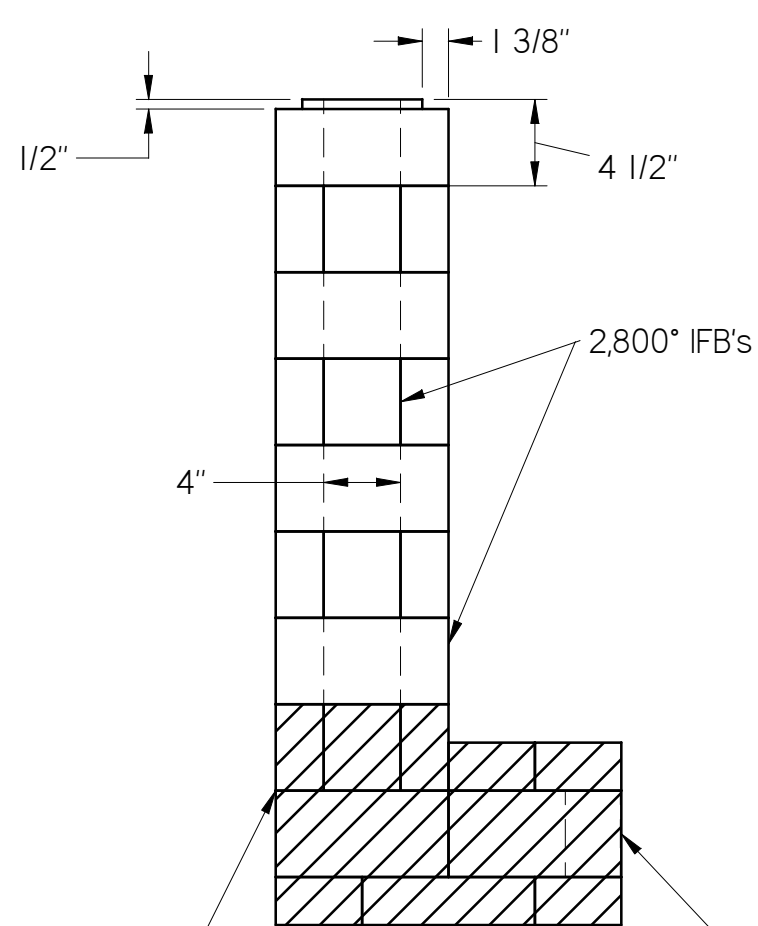
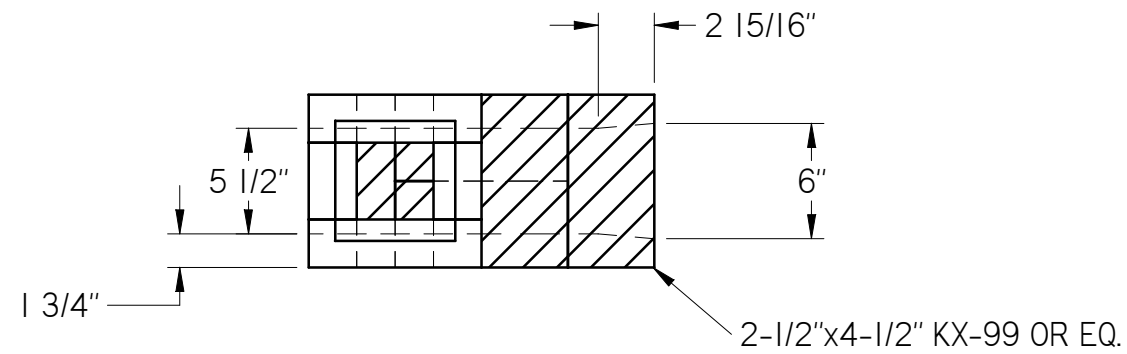

MORTAR ALL HARD BRICK JOINTS

2-1/2"x4-1/2" KX-99 OR EQ.  
CUT THIS ROW TO 1-3/4" THICK  
USE TAMAX IF YOU HAVE EXTRA

THIS DOCUMENT IS FOR THE SOLE USE OF INDIVIDUALS  
AND IS NOT INTENDED TO BE COPIED OR DISTRIBUTED  
WITHOUT PERMISSION FROM SPIRAL ARTS, INC.

<b>975 DAY TANK</b>	<b>SPIRAL ARTS</b>		
	<b>FLUE BRICKS</b>		
LICENSED TO: PUBLIC DOMAIN		<b>FRED METZ 9/13/04</b>	
	Copywrite Spiral Ars 2002		

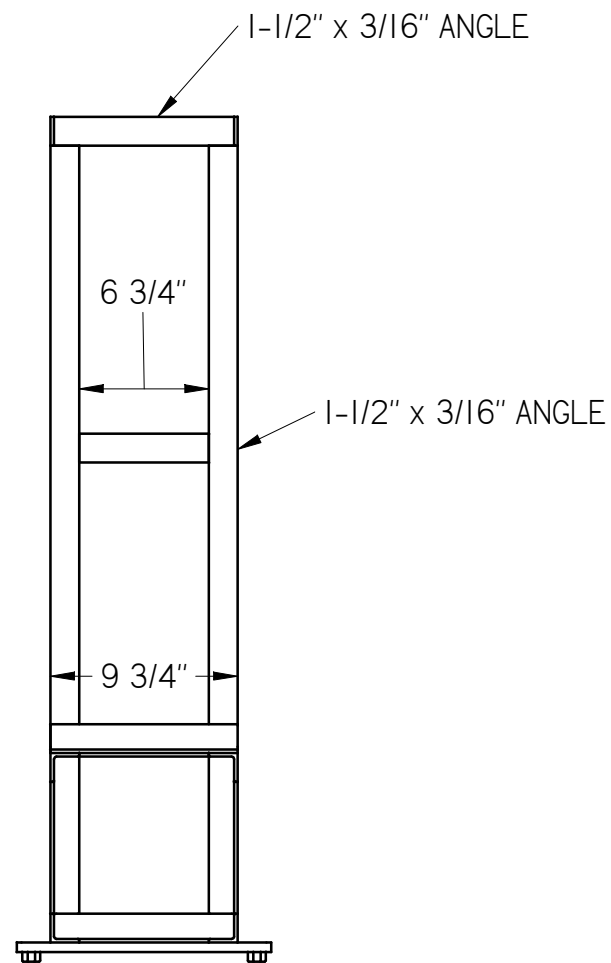
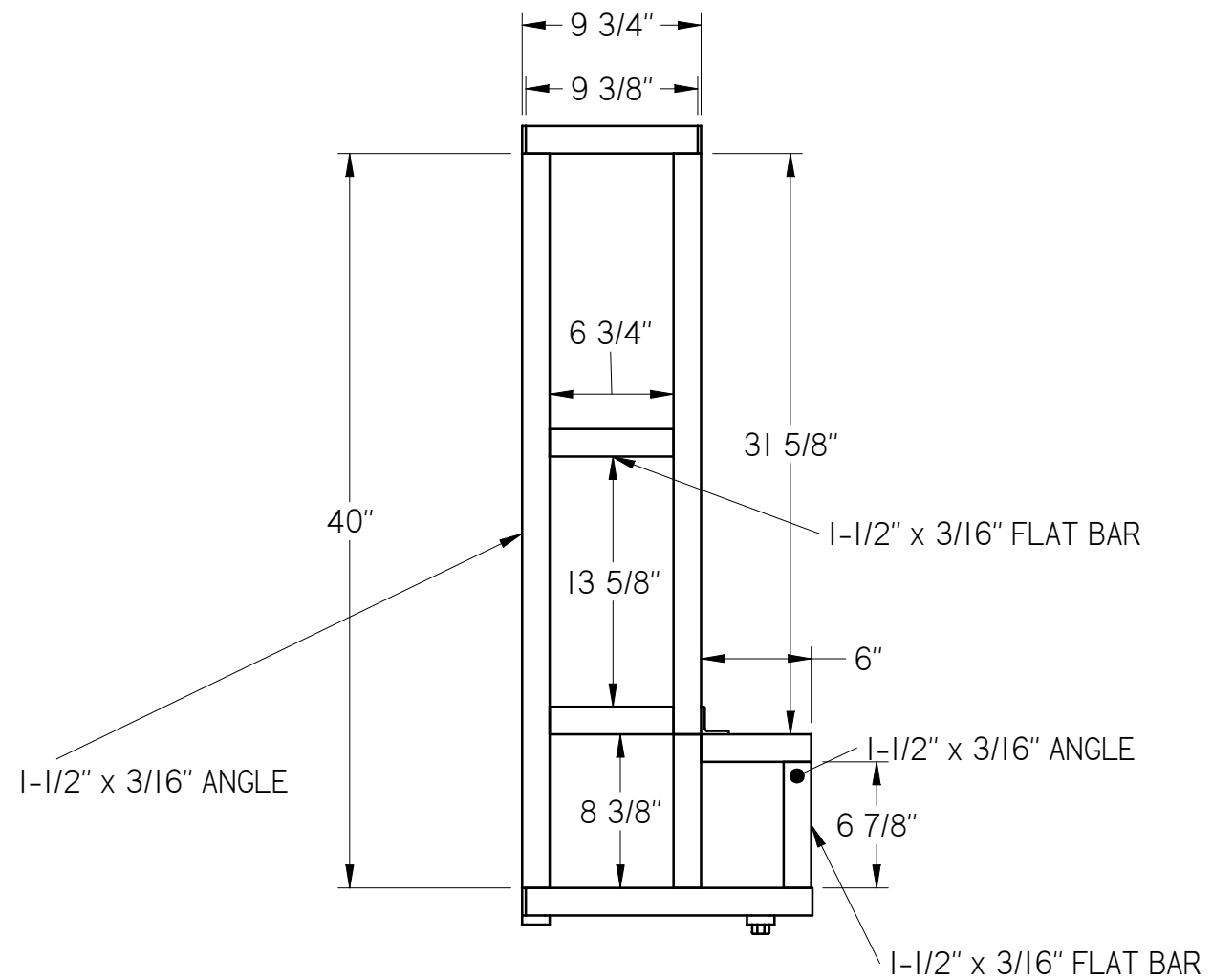
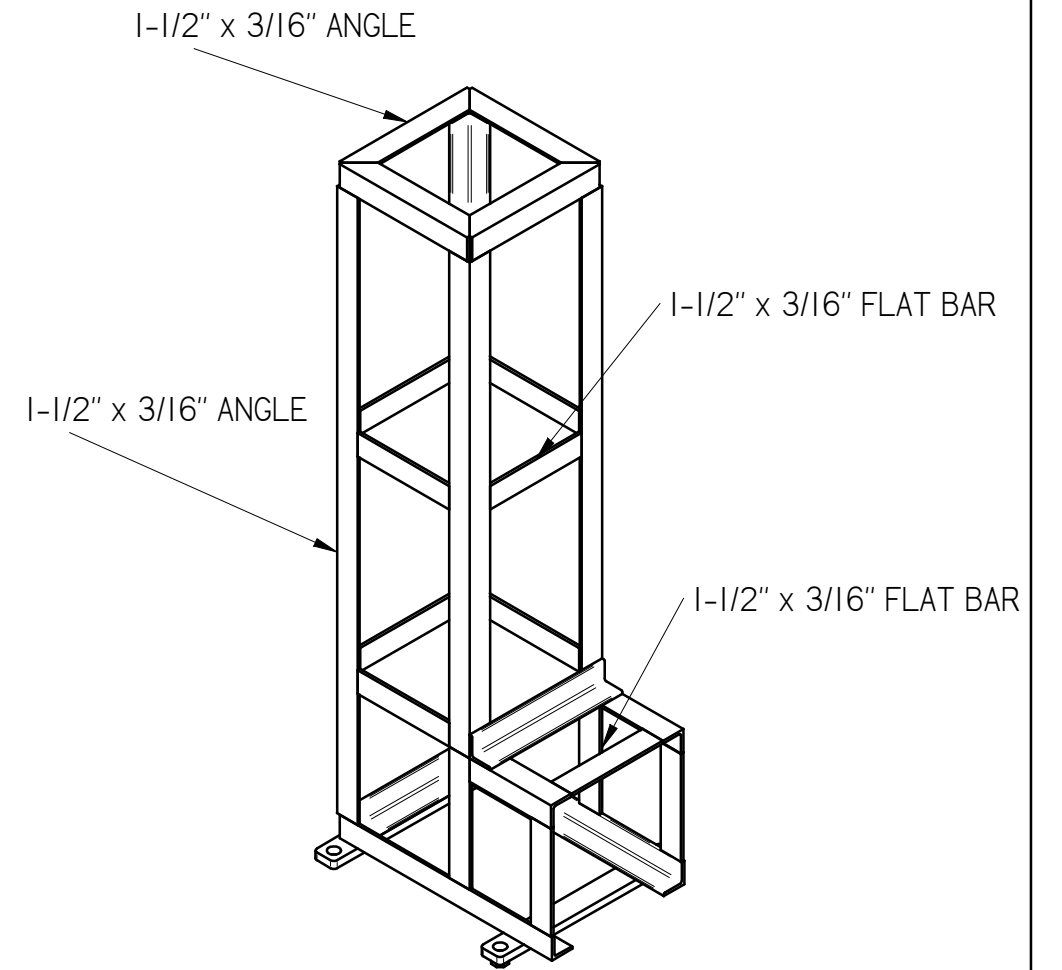
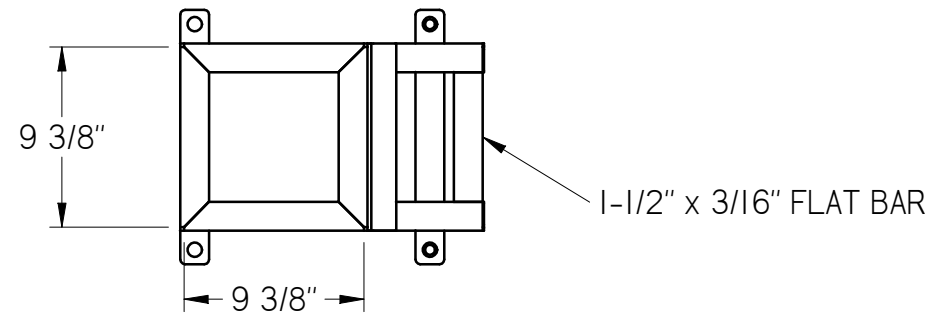

THIS DOCUMENT IS FOR THE SOLE USE OF INDIVIDUALS AND IS NOT INTENDED TO BE COPIED OR DISTRIBUTED WITHOUT PERMISSION FROM SPIRAL ARTS, INC.

975  
DAY TANK

**SPIRAL ARTS**

FLUE STEEL FRAME

LICENSED TO: PUBLIC DOMAIN

FRED METZ 9/13/04

Copyright Spiral Arts 2002