

THIS DOCUMENT IS FOR THE SOLE USE OF INDIVIDUALS
AND IS NOT INTENDED TO BE COPIED OR DISTRIBUTED
WITHOUT PERMISSION FROM SPIRAL ARTS, INC.

975 DAY TANK	SPIRAL ARTS		
	TANK CORE		
LICENSED TO: Public domain		Date 9/14/2005	
File: Tank core assembly.dft		Copyright Spiral Arts 2005	Drawn by Fred Metz

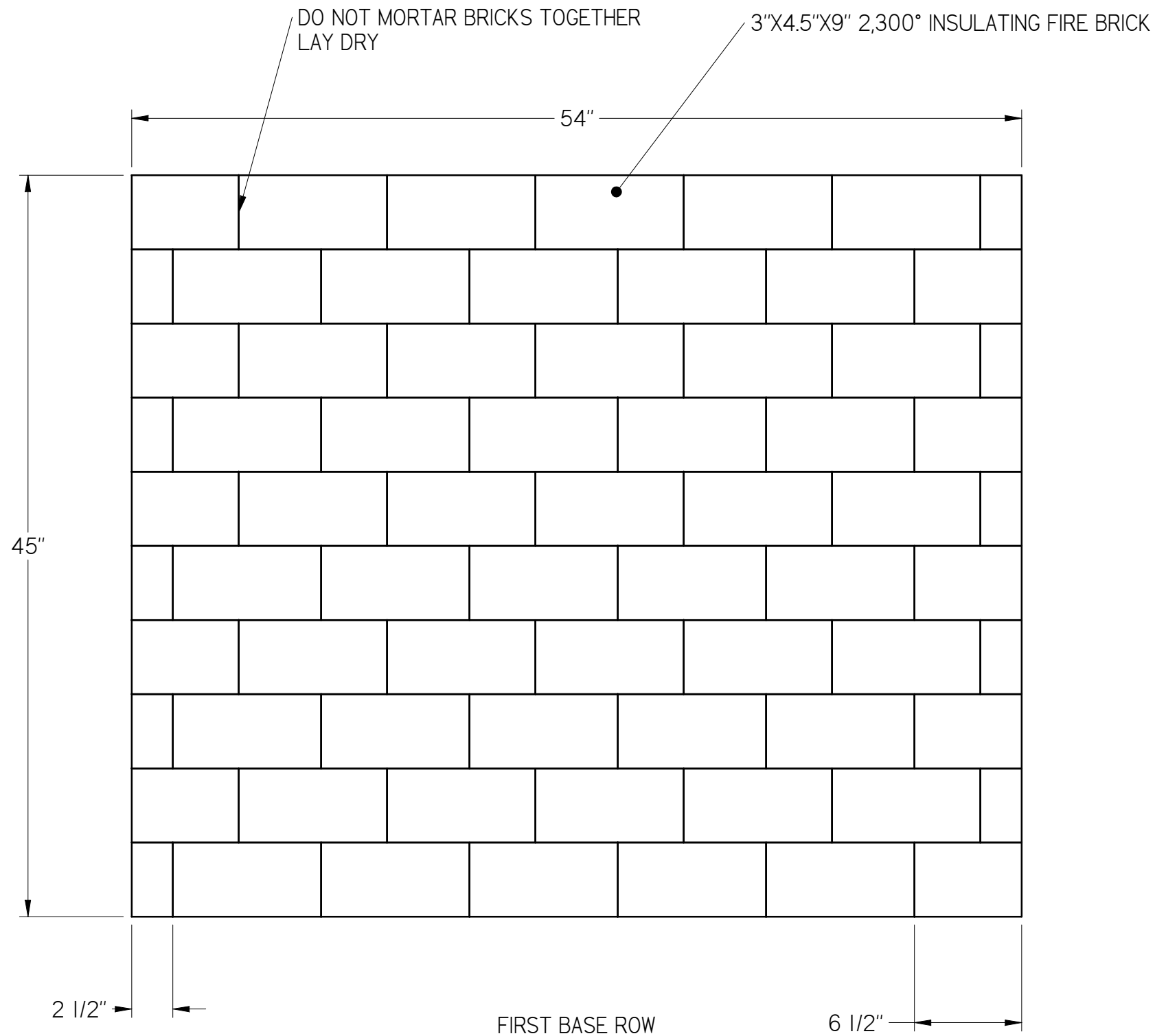

THIS DOCUMENT IS FOR THE SOLE USE OF INDIVIDUALS
AND IS NOT INTENDED TO BE COPIED OR DISTRIBUTED
WITHOUT PERMISSION FROM SPIRAL ARTS, INC.

975 DAY TANK	SPIRAL ARTS		
	TANK CORE 1ST ROW		
LICENSED TO: Public domain		Date 9/14/2005	
File: Tank core assembly.dft		Copyright Spiral Arts 2002	Drawn by Fred Metz

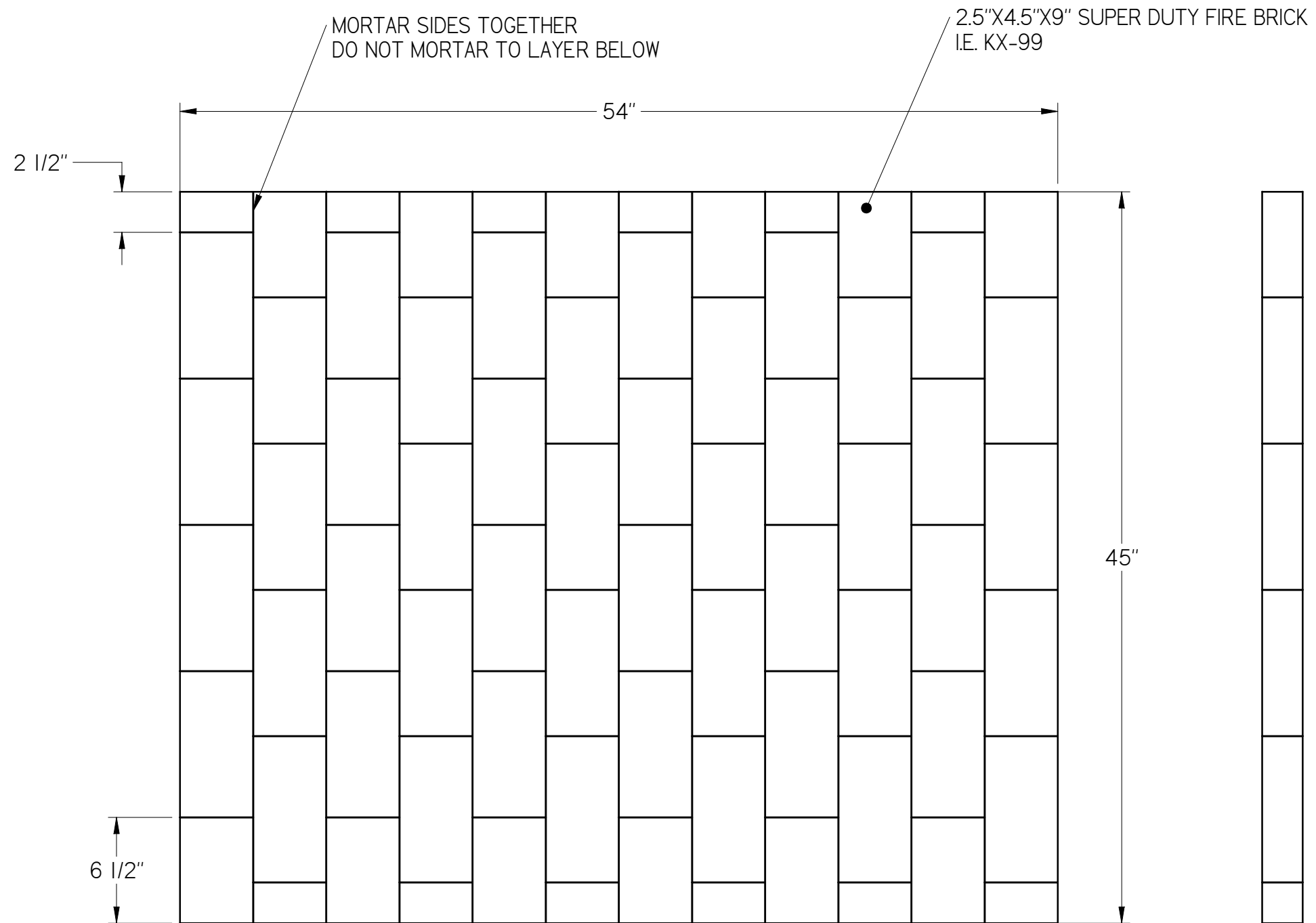

SECOND BASE ROW

THIS DOCUMENT IS FOR THE SOLE USE OF INDIVIDUALS
AND IS NOT INTENDED TO BE COPIED OR DISTRIBUTED
WITHOUT PERMISSION FROM SPIRAL ARTS, INC.

975 DAY TANK	SPIRAL ARTS		
	TANK CORE 2ND ROW		
LICENSED TO: Public domain		Date 9/14/2005	
File: Tank core assembly.dft		Copyright Spiral Arts 2002	Drawn by Fred Metz

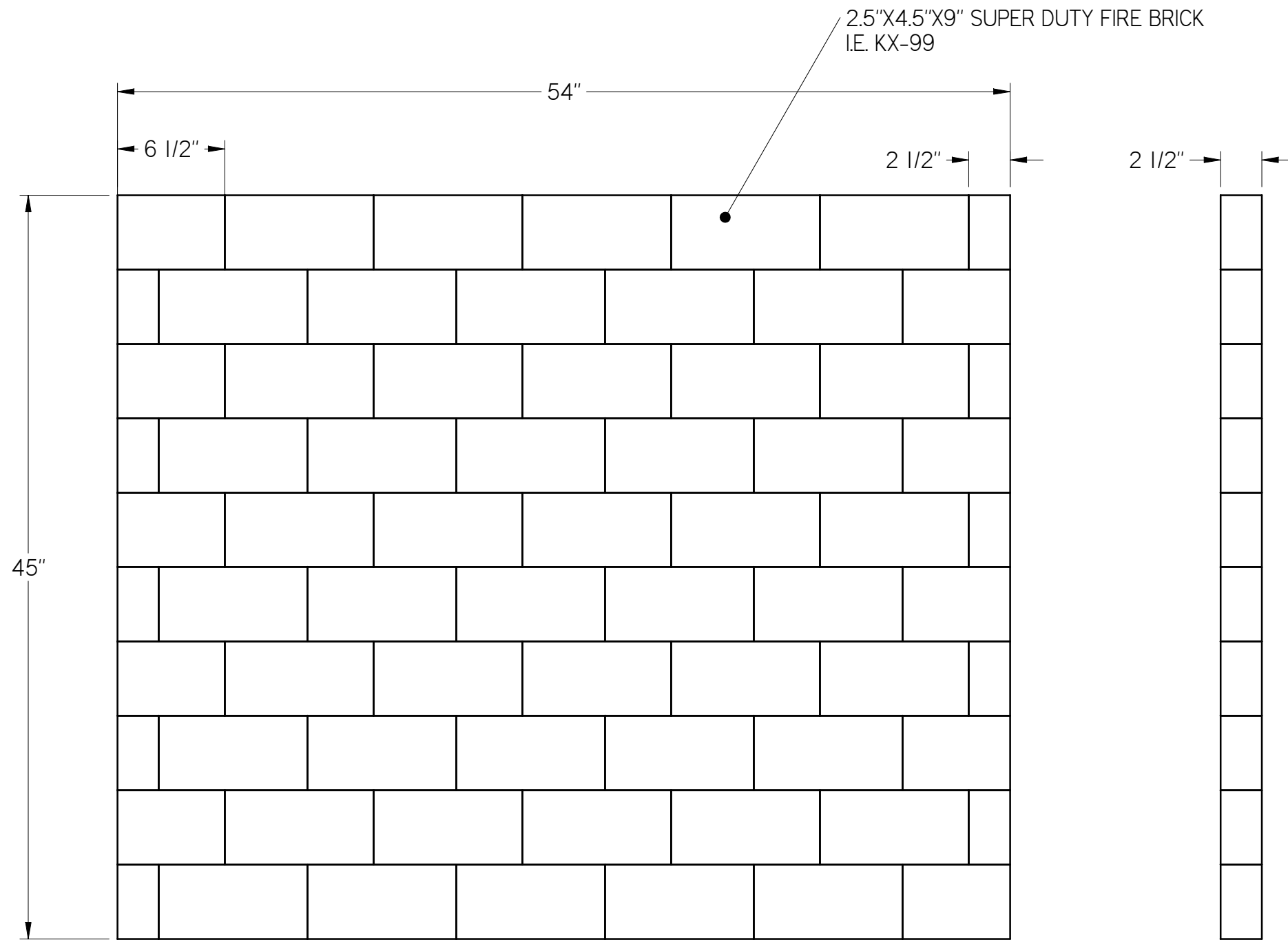

THIRD BASE ROW

MORTAR BRICKS TOGETHER AND TO ROW BENEATH.

THIS DOCUMENT IS FOR THE SOLE USE OF INDIVIDUALS AND IS NOT INTENDED TO BE COPIED OR DISTRIBUTED WITHOUT PERMISSION FROM SPIRAL ARTS, INC.

975 DAY TANK	SPIRAL ARTS		
	TANK CORE 3RD ROW		
LICENSED TO: Public domain		Date 9/14/2005	
File: Tank core assembly.dft		Copyright Spiral Arts 2002	Drawn by Fred Metz

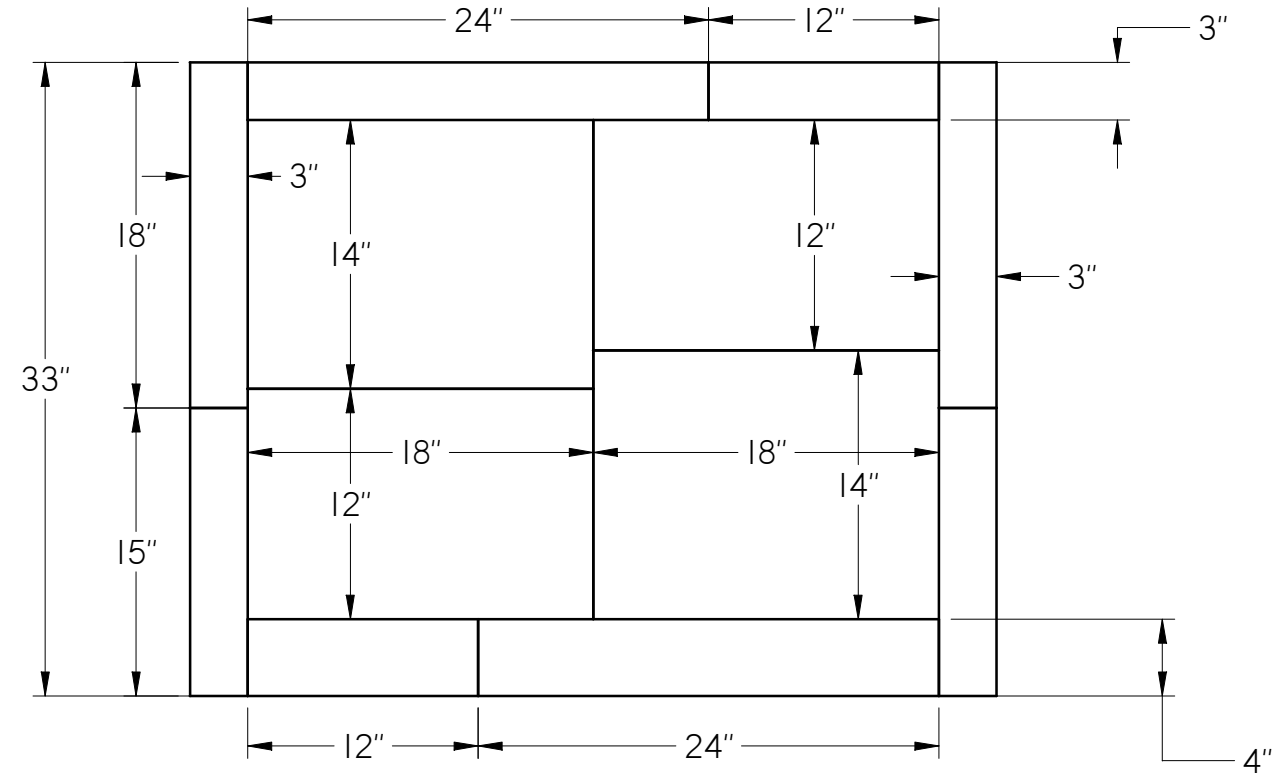

FRONT

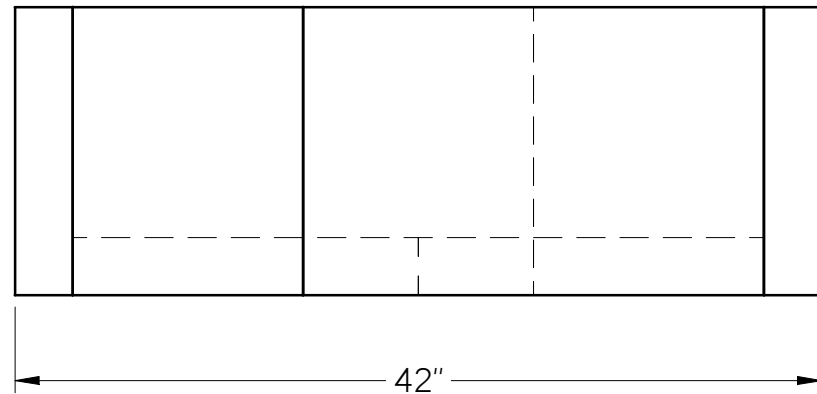

AZS TANK

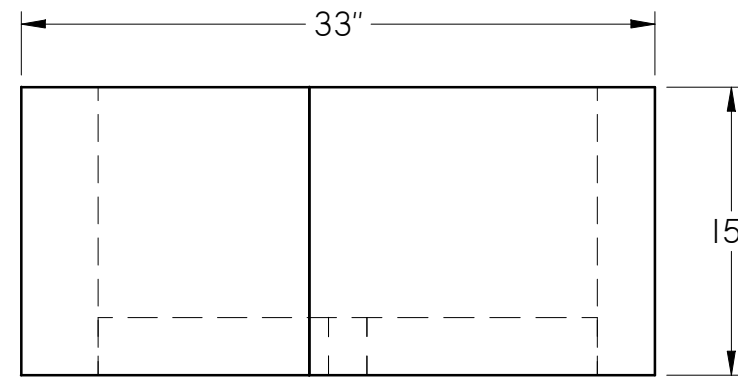
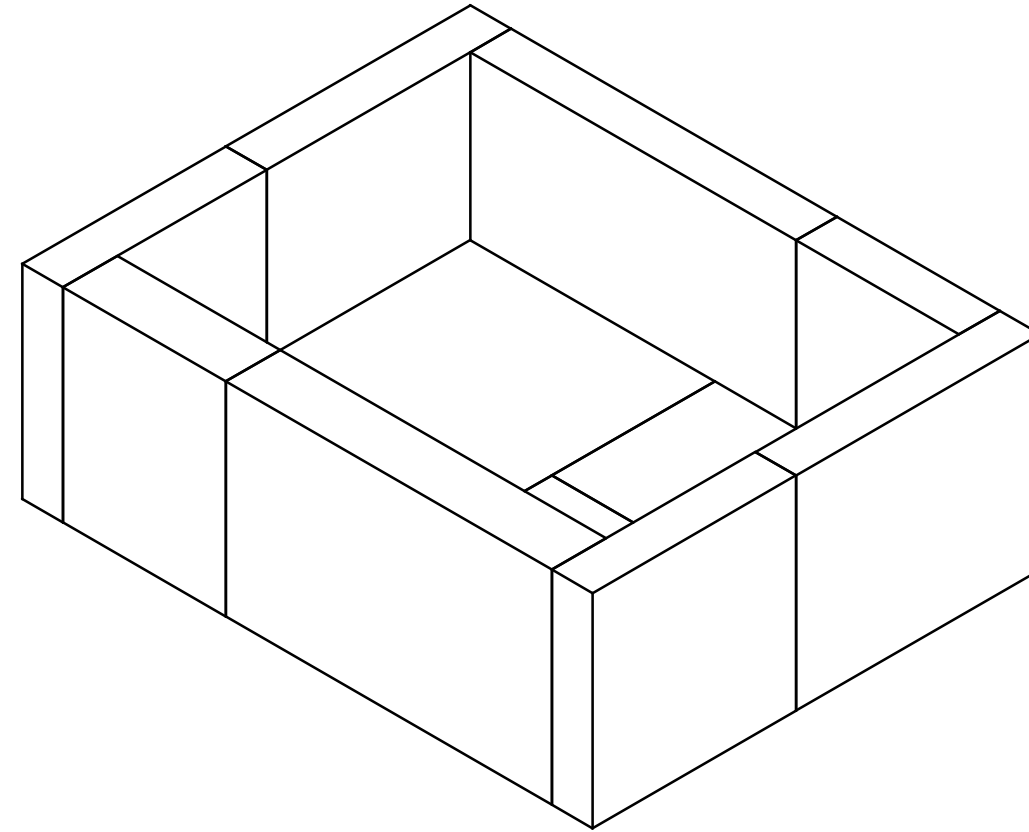

SIDE

BLOCK LIST

- (1) 12"x15"x4" CS4
- (1) 24"x15"x4" CS4
- (2) 15"x15"x3" CS4
- (2) 18"x15"x3" CS4
- (1) 12"x15"x3" CS4
- (1) 24"x15"x3" CS4
- (2) 14"x18"x3" CS3
- (2) 12"x18"x3" CS3

ALL BLOCKS VOID FREE DCL TILE
 ALL MATEING SURFACES GOUND TO MATCH
 1/32" JOINT TOLLERANCE

AZS IS LAYED IN 3/16" THICK BED OF HMS HEAT SET CEMENT. DO NOT MORTAR JOINTS TOGETHER! BLOCKS SHOULD HAVE NO MORE THAN 1/32" GAP.

TANK IS CENTERED ON BASE BRICK BELOW IT.

THIS DOCUMENT IS FOR THE SOLE USE OF INDIVIDUALS AND IS NOT INTENDED TO BE COPIED OR DISTRIBUTED WITHOUT PERMISSION FROM SPIRAL ARTS, INC.

975 DAY TANK	SPIRAL ARTS		
	TANK CORE AZS		
LICENSED TO: Public domain		Date 9/14/2005	
File: Tank core assembly.dft	Copyright Spiral Arts 2002	Drawn by Fred Metz	

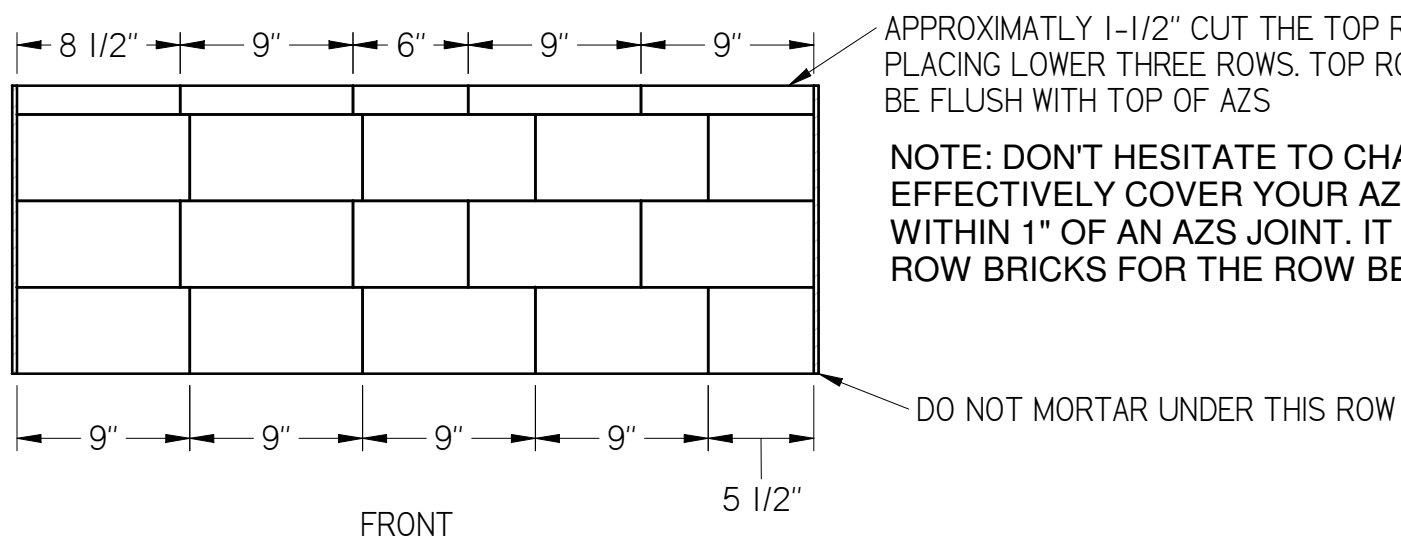
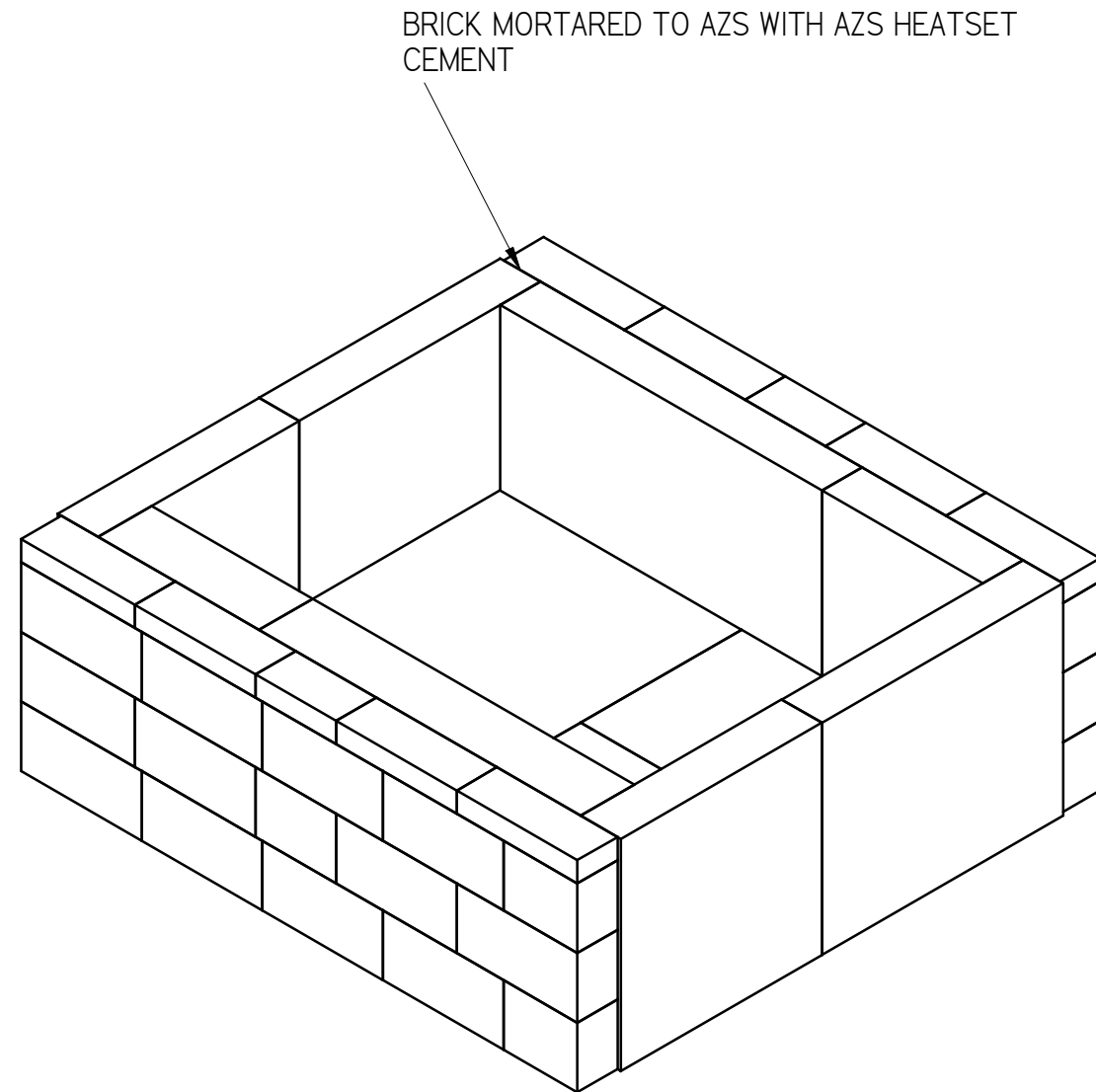
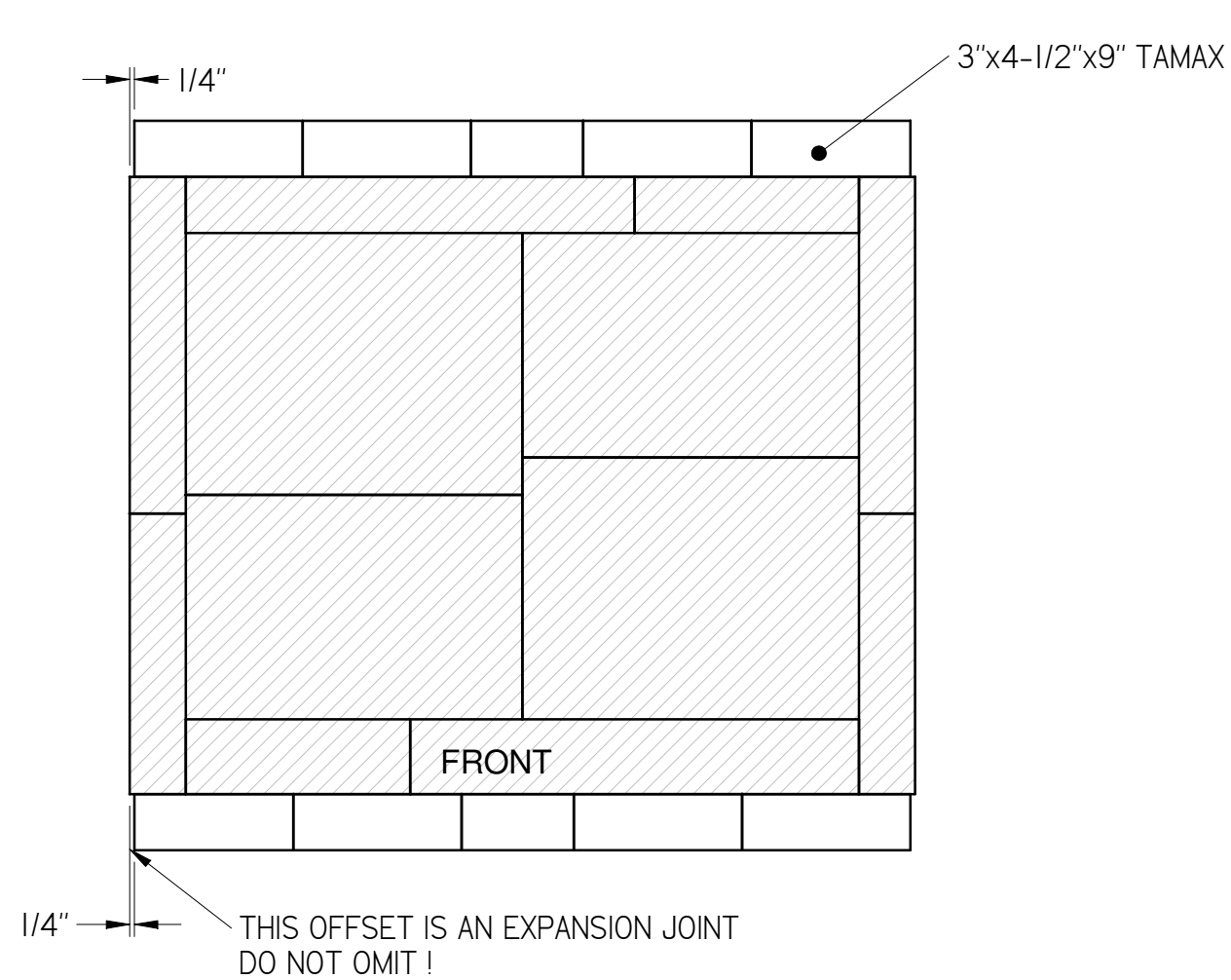

THIS DOCUMENT IS FOR THE SOLE USE OF INDIVIDUALS AND IS NOT INTENDED TO BE COPIED OR DISTRIBUTED WITHOUT PERMISSION FROM SPIRAL ARTS, INC.

975 DAY TANK	SPIRAL ARTS		
	FRONT AND REAR TANK TAMAX		
LICENSED TO: Public domain		Date 9/14/2005	
File: Tank core assembly.dft		Copyright Spiral Arts 2002	Drawn by Fred Metz

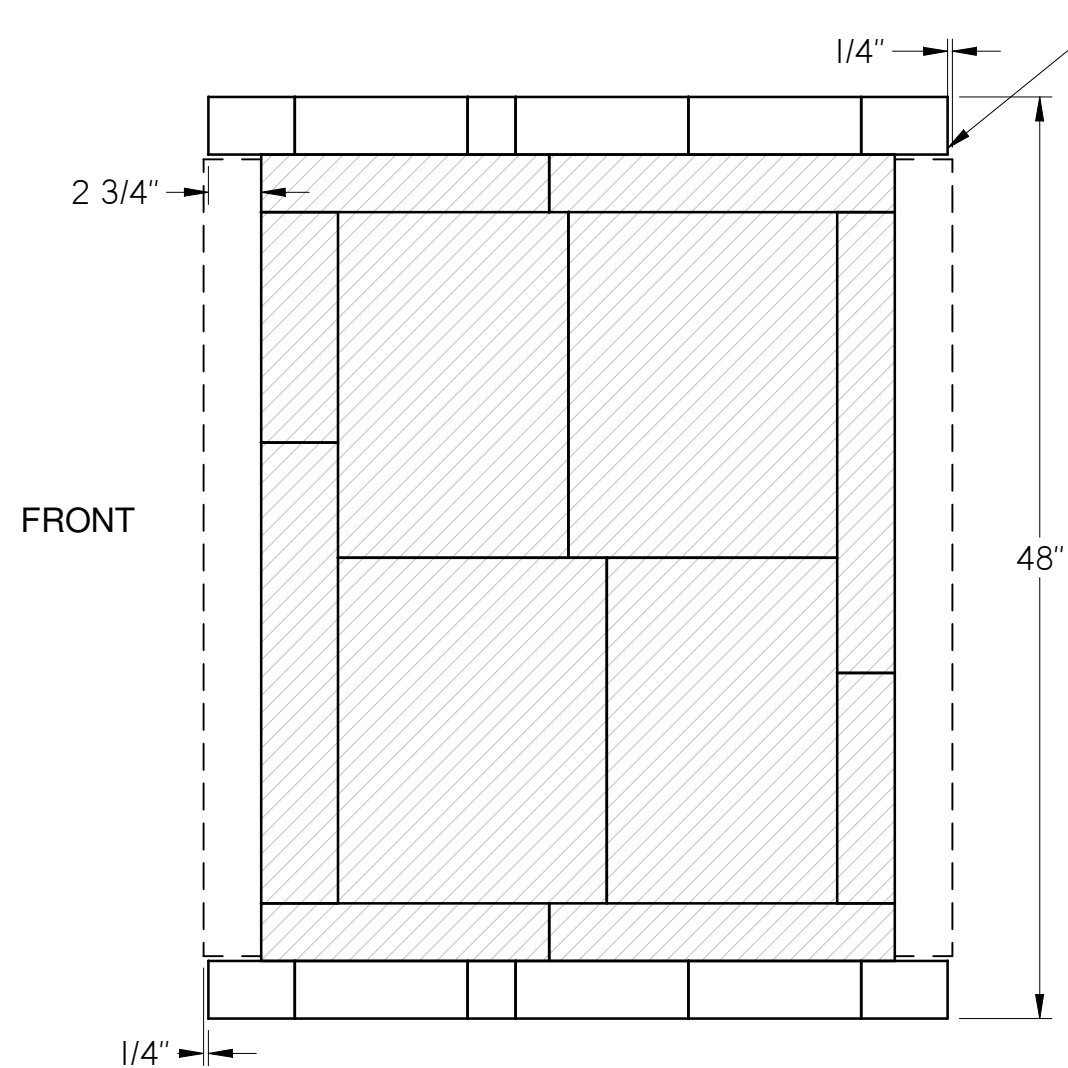

THIS ROW ENDS 1/4" SHORT OF FRONT AND BACK TAMAX ROWS TO ACCOMODATE FOR EXPANSION JOINT - DO NOT OMIT !

BRICK MORTARED TO AZS WITH AZS HEATSET CEMENT

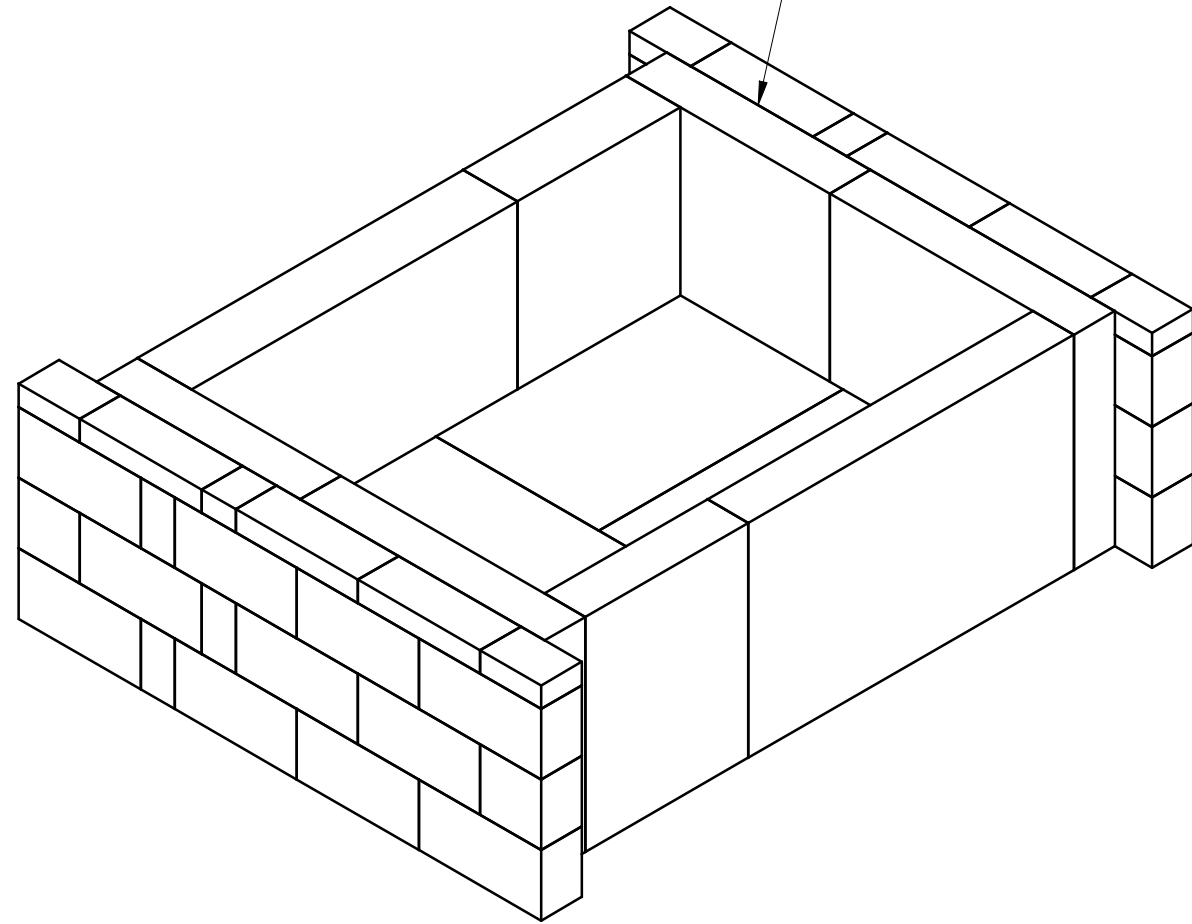

THIS DOCUMENT IS FOR THE SOLE USE OF INDIVIDUALS AND IS NOT INTENDED TO BE COPIED OR DISTRIBUTED WITHOUT PERMISSION FROM SPIRAL ARTS, INC.

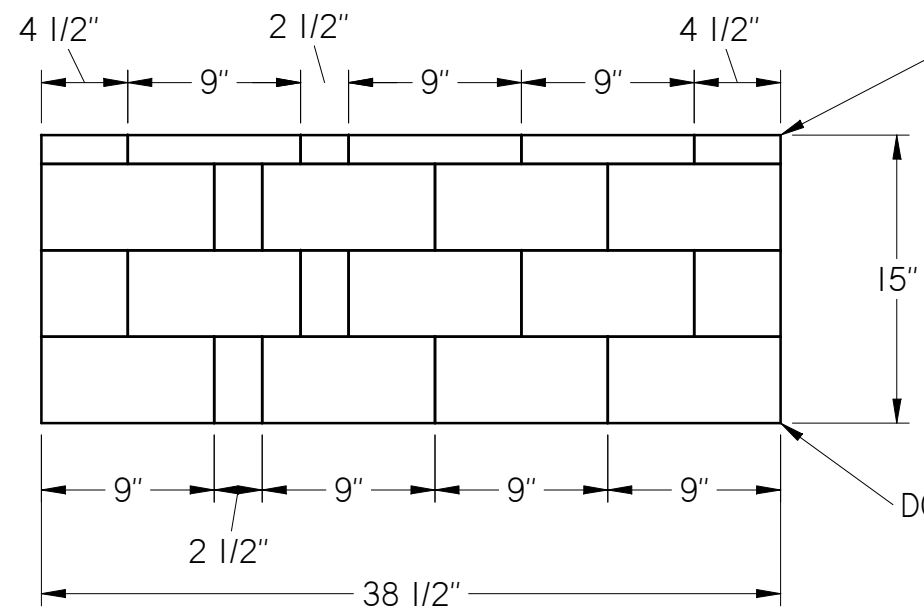

APPROXIMATLEY 1-1/2" CUT AFTER PLACING LOWER ROWS - BRICKS SHOULD BE FLUSH WITH TOP OF AZS

NOTE: DON'T HESITATE TO CHANGE THIS LAYOUT PATTERN TO MORE EFFECTIVELY COVER YOUR AZS JOINTS. THERE SHOULD BE NO TAMAX JOINT WITHIN 1" OF AN AZS JOINT. IT IS ALSO ADVISABLE TO SWAP THE THIN TOP ROW BRICKS FOR THE ROW BENEATH.

DO NOT MORTAR UNDER THIS ROW

975 DAY TANK	SPIRAL ARTS		
	SIDE TANK TAMAX		
LICENSED TO: Public domain		Date 9/14/2005	
File: Tank core assembly.dft	Copywrite Spiral Arts 2002	Drawn by Fred Metz	

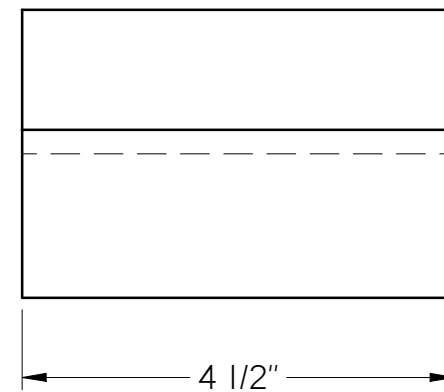
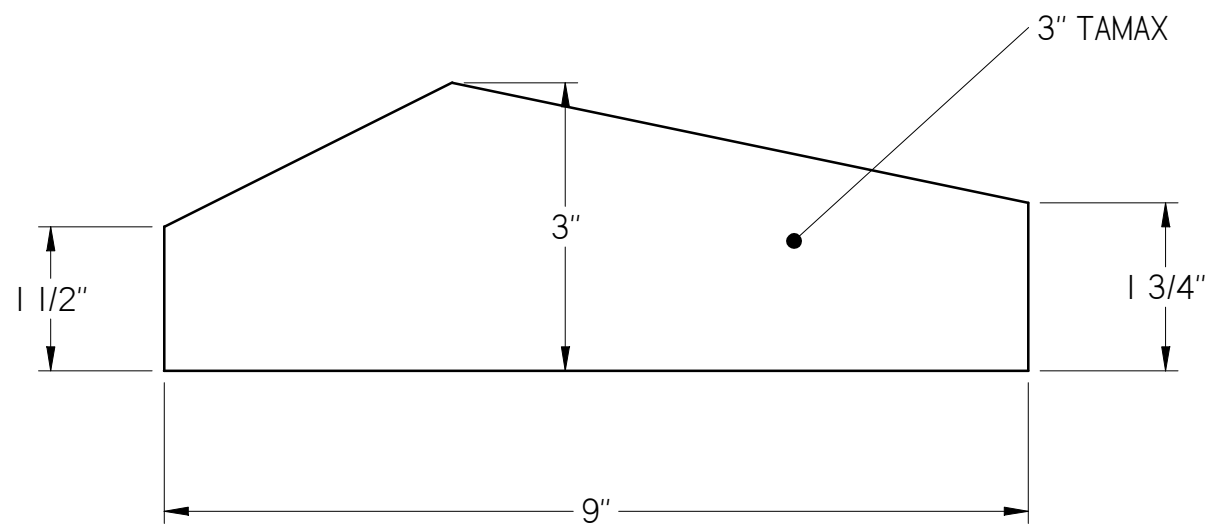
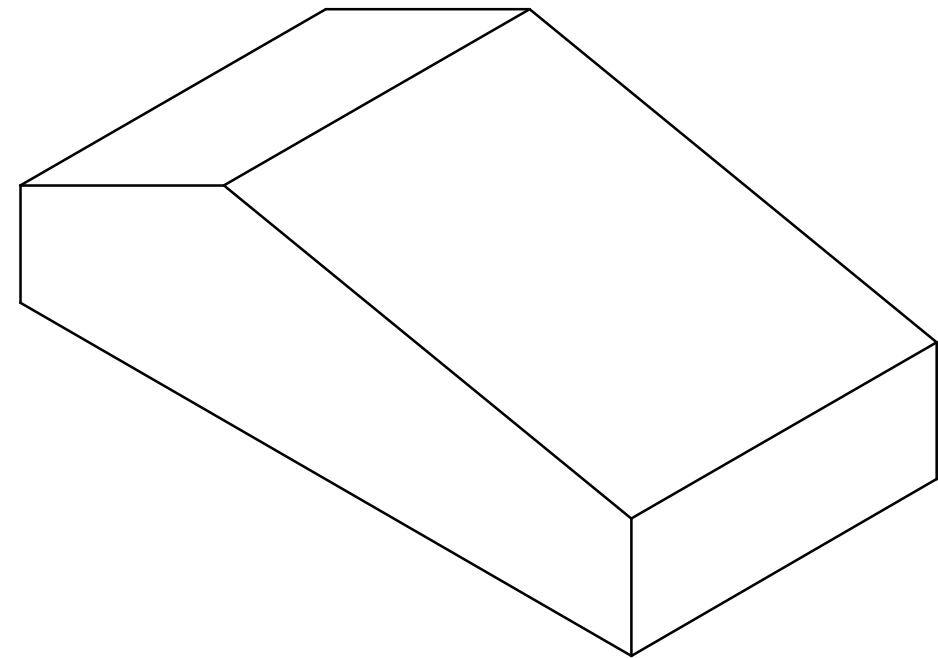
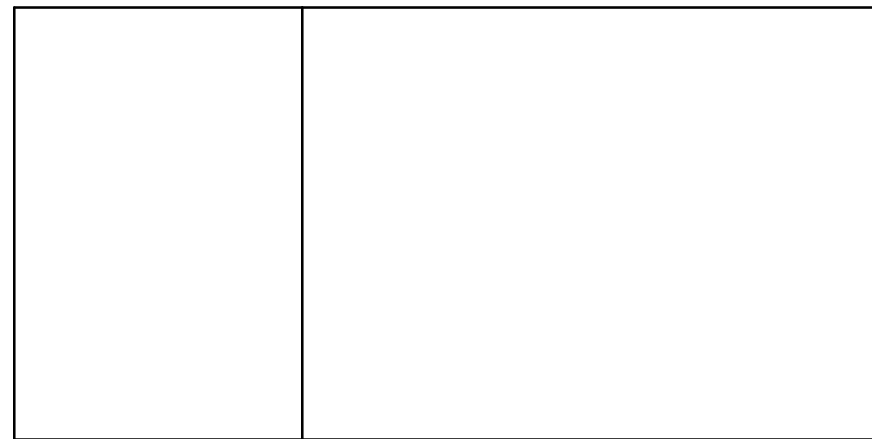

THIS DOCUMENT IS FOR THE SOLE USE OF INDIVIDUALS
AND IS NOT INTENDED TO BE COPIED OR DISTRIBUTED
WITHOUT PERMISSION FROM SPIRAL ARTS, INC.

975 DAY TANK	SPIRAL ARTS		
	SILL BRICK		
LICENSED TO: Public domain		Date 9/14/2005	
File: Tank core assembly.dft		Copyright Spiral Arts 2002	Drawn by Fred Metz

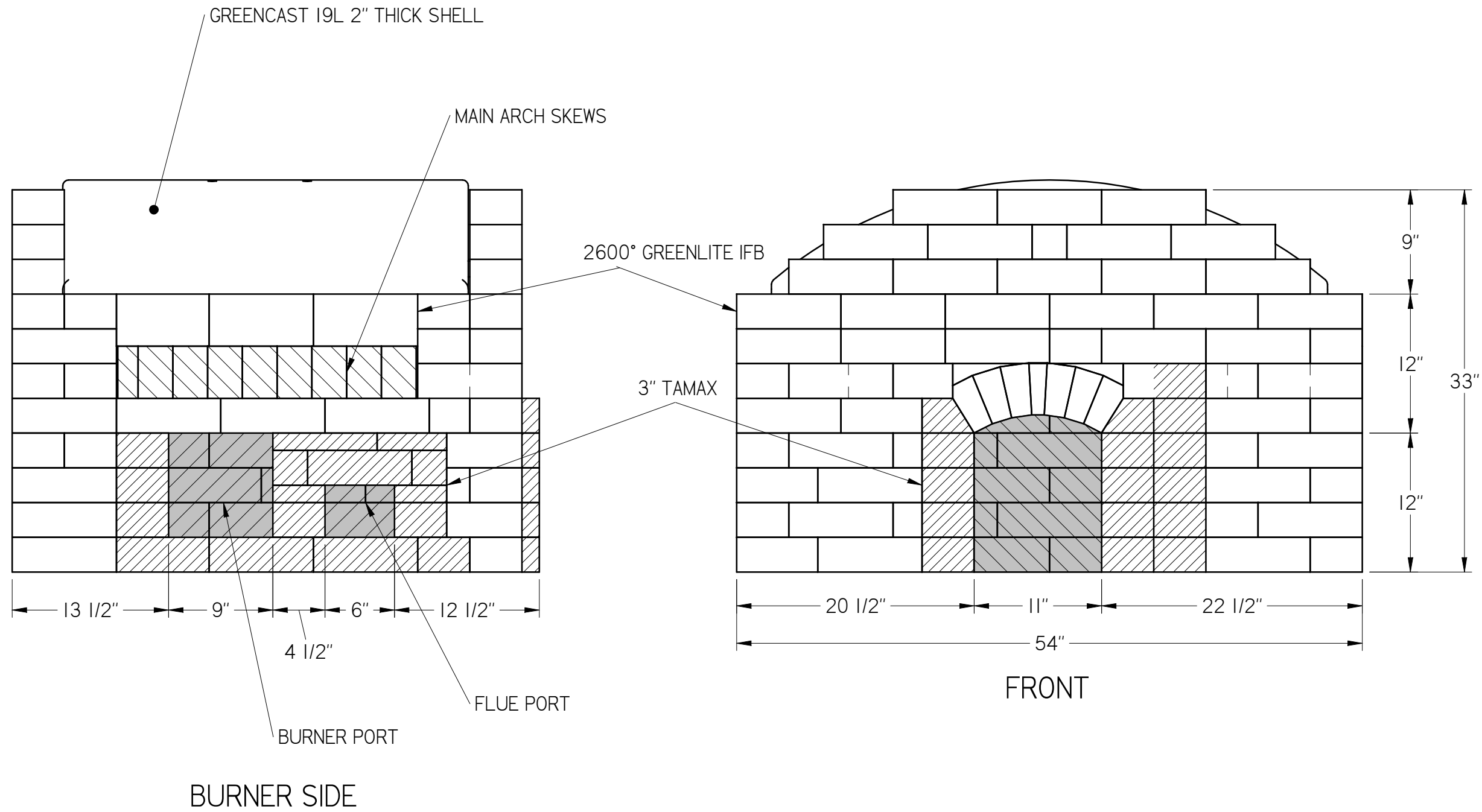

THIS DOCUMENT IS FOR THE SOLE USE OF INDIVIDUALS AND IS NOT INTENDED TO BE COPIED OR DISTRIBUTED WITHOUT PERMISSION FROM SPIRAL ARTS, INC.

975 DAY TANK	SPIRAL ARTS		
	CROWN		
LICENSED TO: Public domain		Date 9/14/2005	
File: Tank core assembly.dft		Copyright Spiral Arts 2002	Drawn by Fred Metz

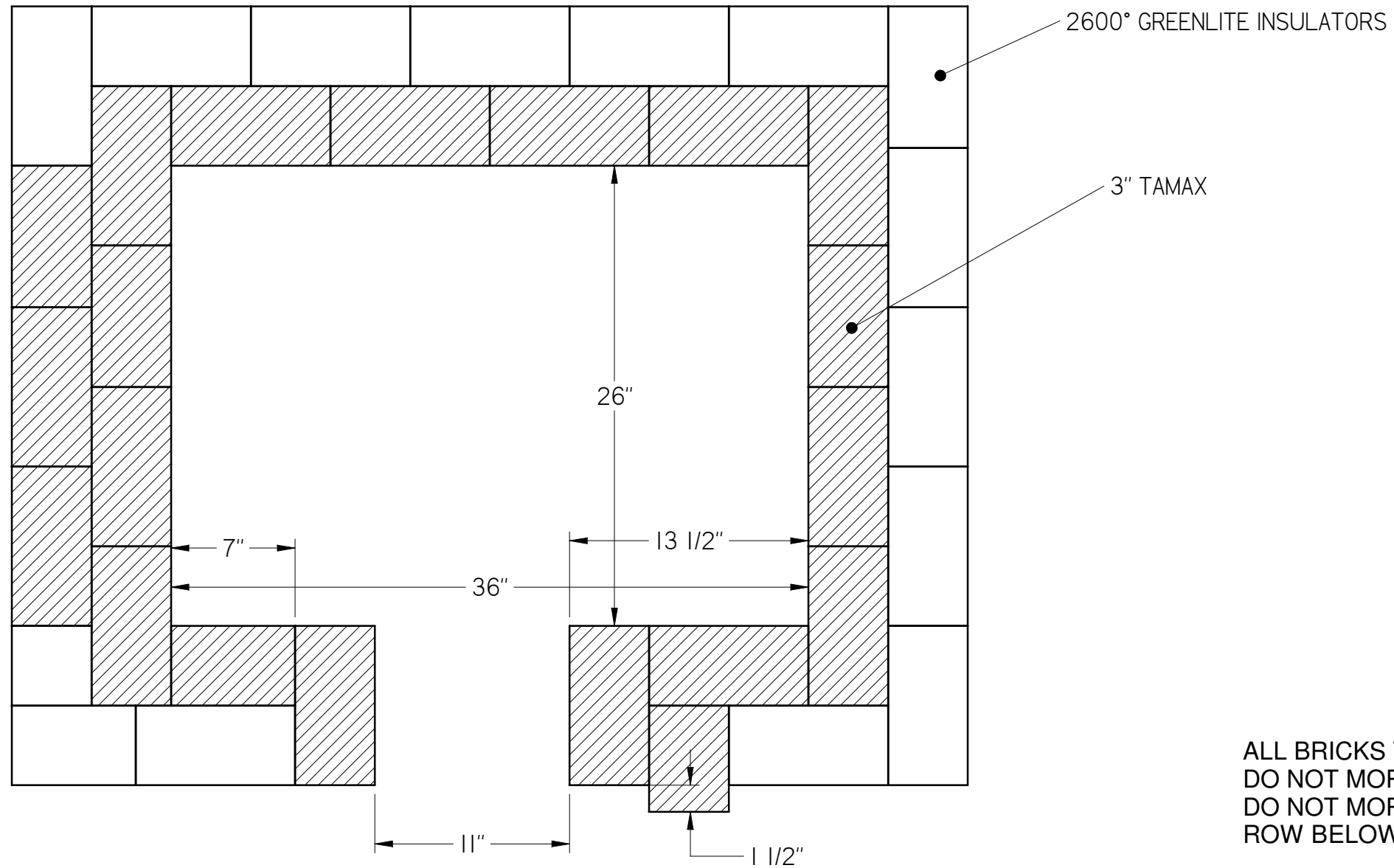

ALL BRICKS TO BE MORTARED IN PLACE -
DO NOT MORTAR INSULATORS TO TAMAX,
DO NOT MORTAR INSULATORS TO TANK
ROW BELOW.

THIS DOCUMENT IS FOR THE SOLE USE OF INDIVIDUALS
AND IS NOT INTENDED TO BE COPIED OR DISTRIBUTED
WITHOUT PERMISSION FROM SPIRAL ARTS, INC.

975 DAY TANK	<i>SPIRAL ARTS</i>		
	1st ROW CROWN		
LICENSED TO: Public domain		Date 9/14/2005	
File: Tank core assembly.dft		Copyright Spiral Arts 2002	Drawn by Fred Metz

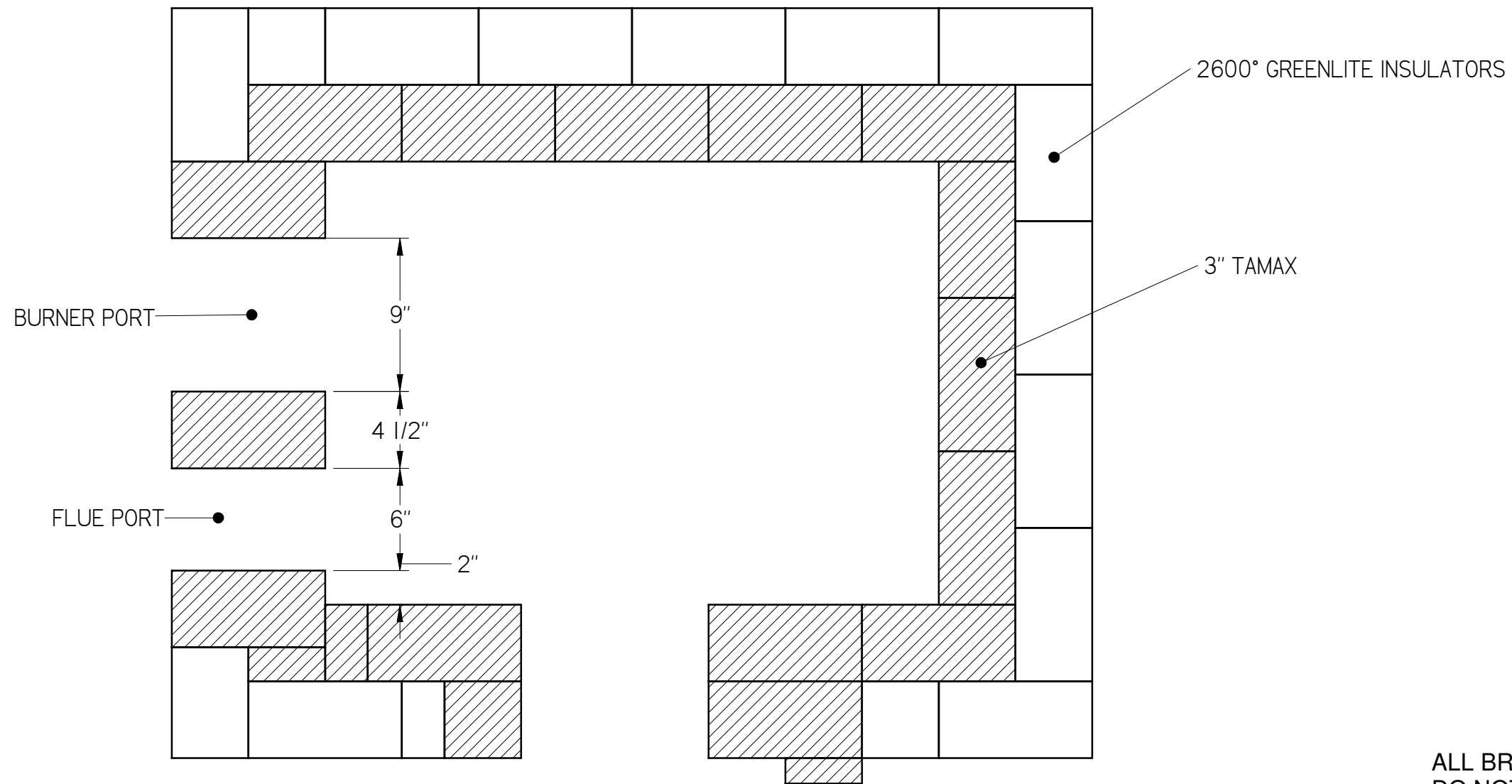

ALL BRICKS TO BE MORTARED IN PLACE -
DO NOT MORTAR INSULATORS TO TAMAX

2nd ROW

THIS DOCUMENT IS FOR THE SOLE USE OF INDIVIDUALS
AND IS NOT INTENDED TO BE COPIED OR DISTRIBUTED
WITHOUT PERMISSION FROM SPIRAL ARTS, INC.

975 DAY TANK	<i>SPIRAL ARTS</i>		
	2nd ROW CROWN		
LICENSED TO: Public domain		Date 9/14/2005	
File: Tank core assembly.dft		Copyright Spiral Arts 2002	Drawn by Fred Metz

2600° GREENLITE INSULATORS

3" TAMAX

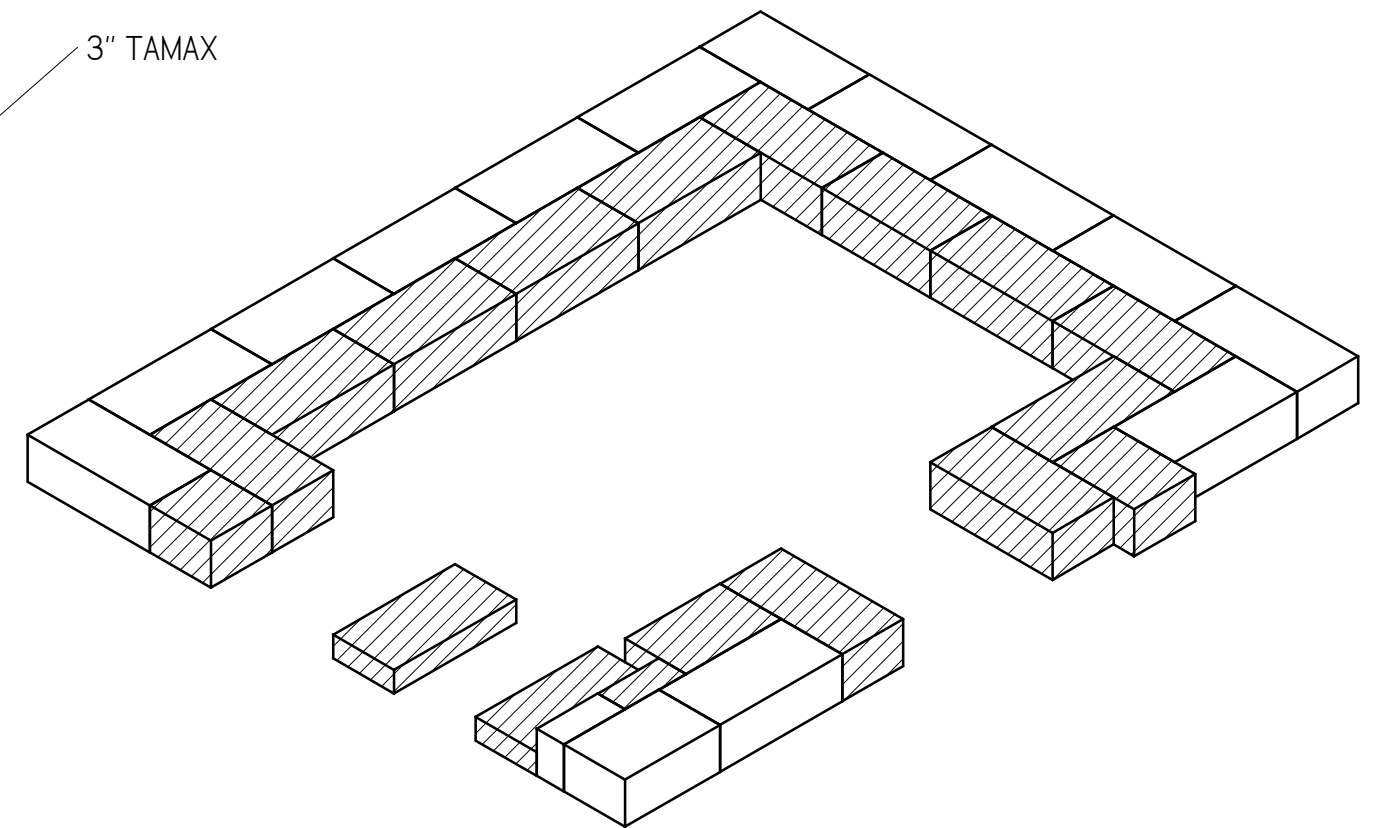
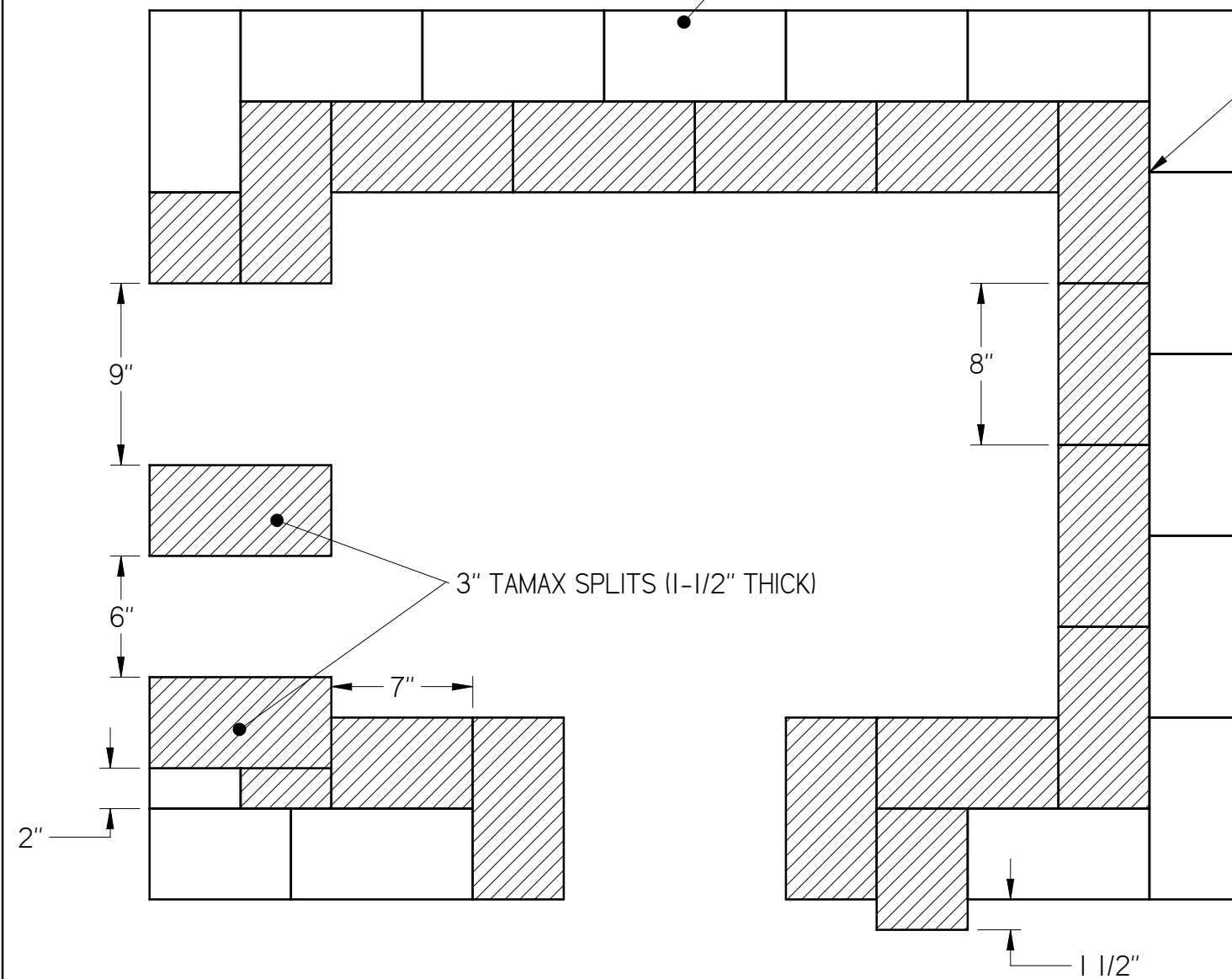

ALL BRICKS TO BE MORTARED IN PLACE -
DO NOT MORTAR INSULATORS TO TAMAX

3rd ROW

THIS DOCUMENT IS FOR THE SOLE USE OF INDIVIDUALS
AND IS NOT INTENDED TO BE COPIED OR DISTRIBUTED
WITHOUT PERMISSION FROM SPIRAL ARTS, INC.

975 DAY TANK	SPIRAL ARTS		
	3rd ROW CROWN		
LICENSED TO: Public domain		Date 9/14/2005	
File: Tank core assembly.dft		Copyright Spiral Arts 2002	Drawn by Fred Metz

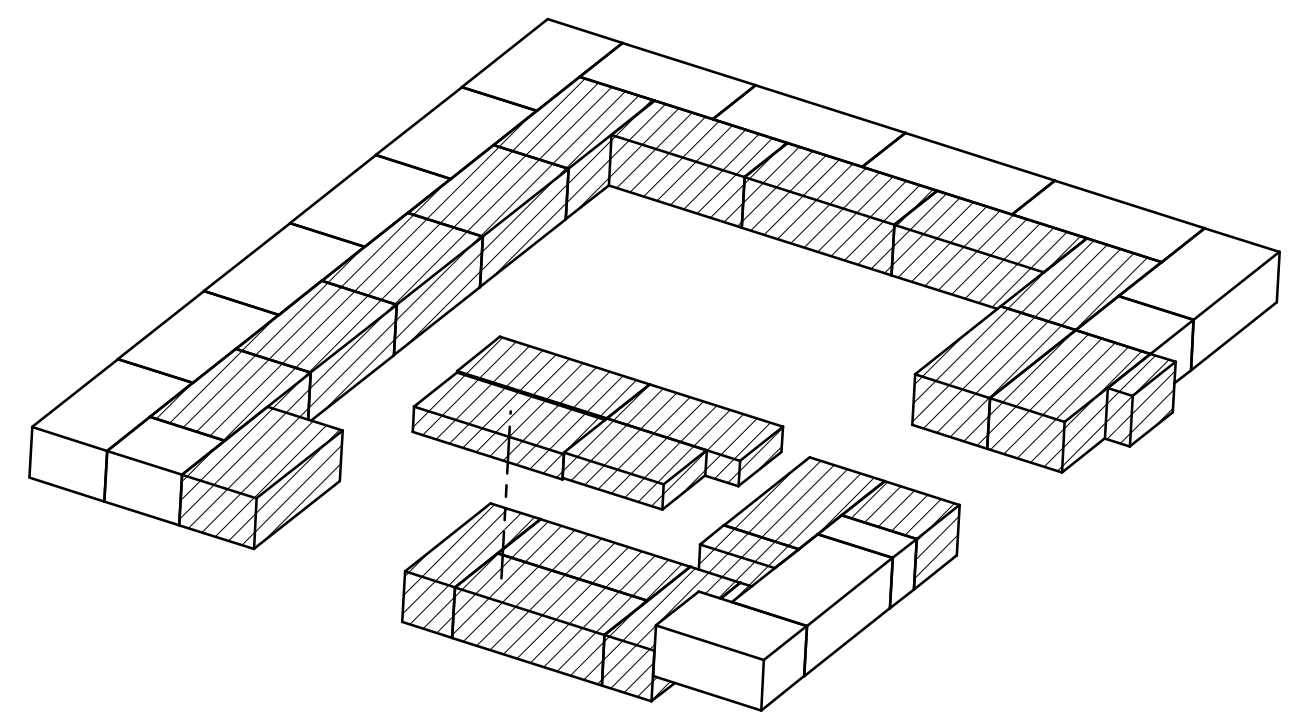
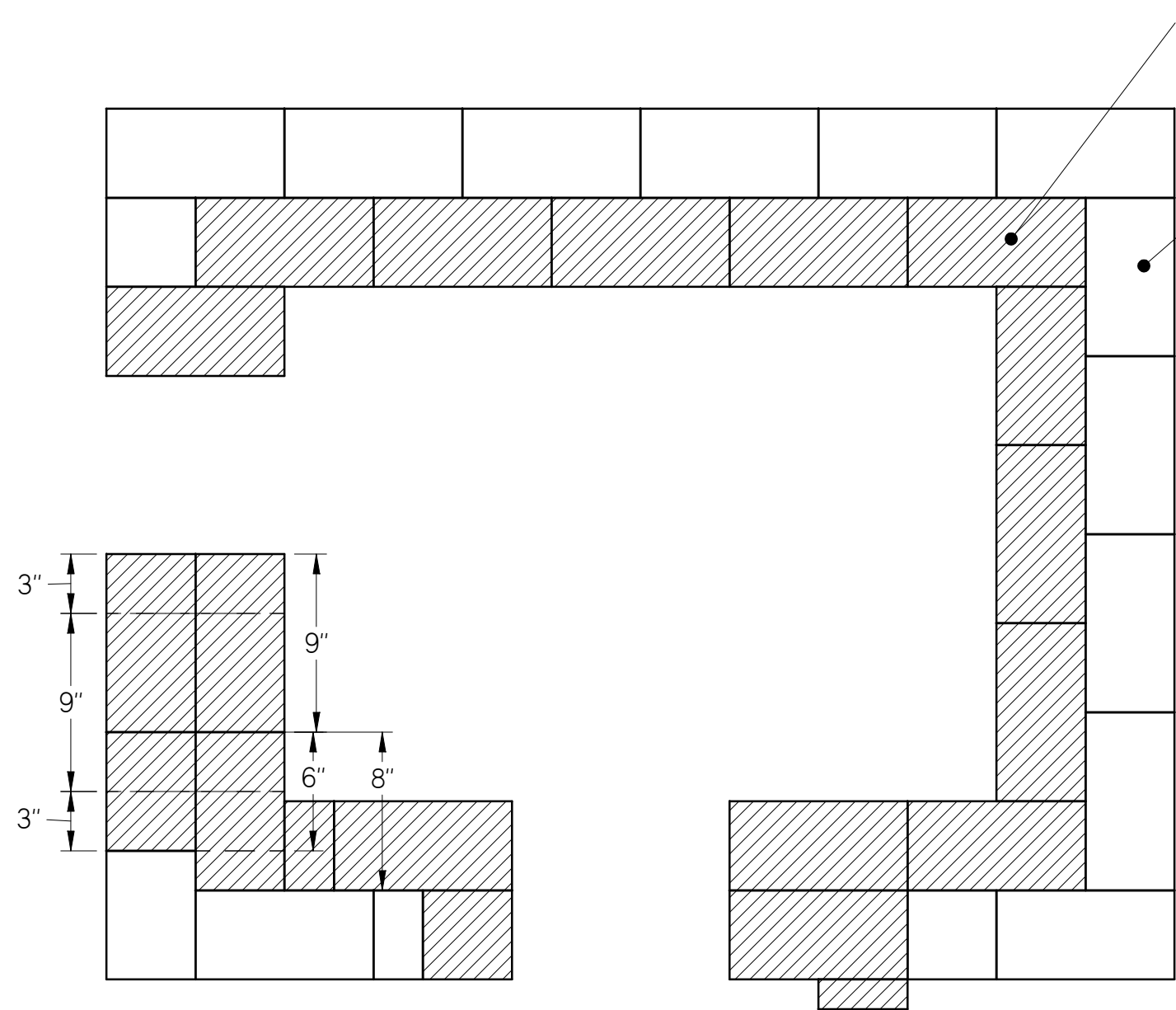

ALL BRICKS TO BE MORTARED IN PLACE -
DO NOT MORTAR INSULATORS TO TAMAX

975 DAY TANK	SPIRAL ARTS		
	4th ROW CROWN		
LICENSED TO: Public domain		Date 9/14/2005	
File: Tank core assembly.dft		Copyright Spiral Arts 2002	Drawn by Fred Metz

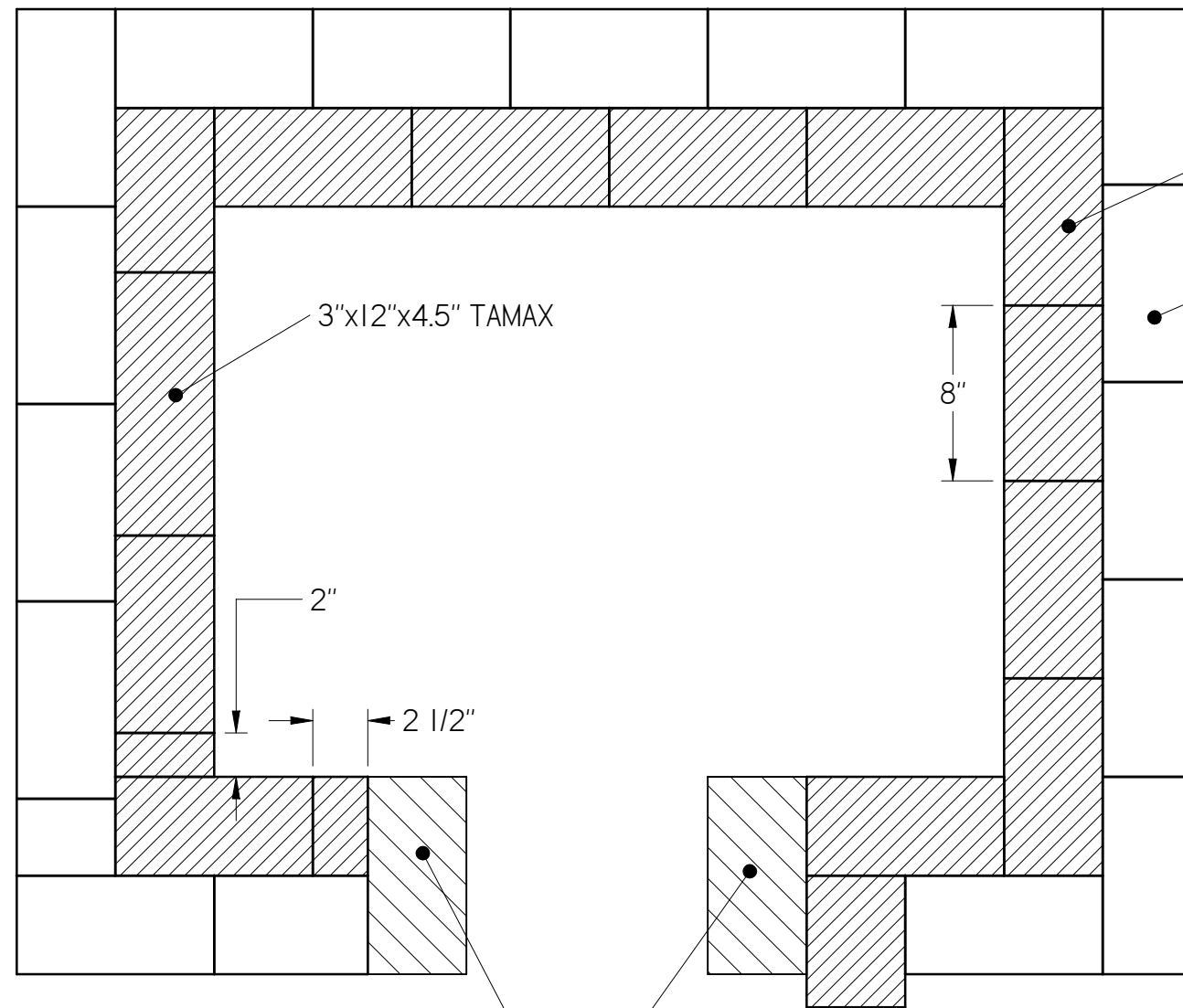

3" TAMAX

2600° GREENLITE INSULATORS

3"x12"x4.5" TAMAX

8"

2"

2 1/2"

ALL BRICKS TO BE MORTARED IN PLACE -
DO NOT MORTAR INSULATORS TO TAMAX

DOOR SKEWS - SEE DOOR ARCH DRAWING

THIS DOCUMENT IS FOR THE SOLE USE OF INDIVIDUALS
AND IS NOT INTENDED TO BE COPIED OR DISTRIBUTED
WITHOUT PERMISSION FROM SPIRAL ARTS, INC.

975 DAY TANK	<i>SPIRAL ARTS</i>		
	5th ROW CROWN		
LICENSED TO: Public domain		Date 9/14/2005	
File: Tank core assembly.dft		Copyright Spiral Arts 2002	Drawn by Fred Metz

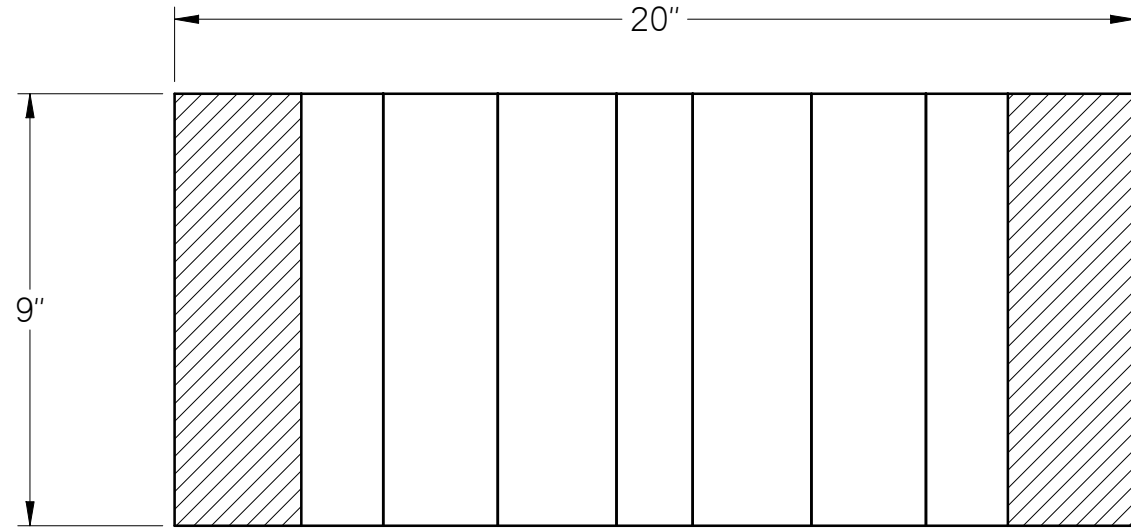

TOP

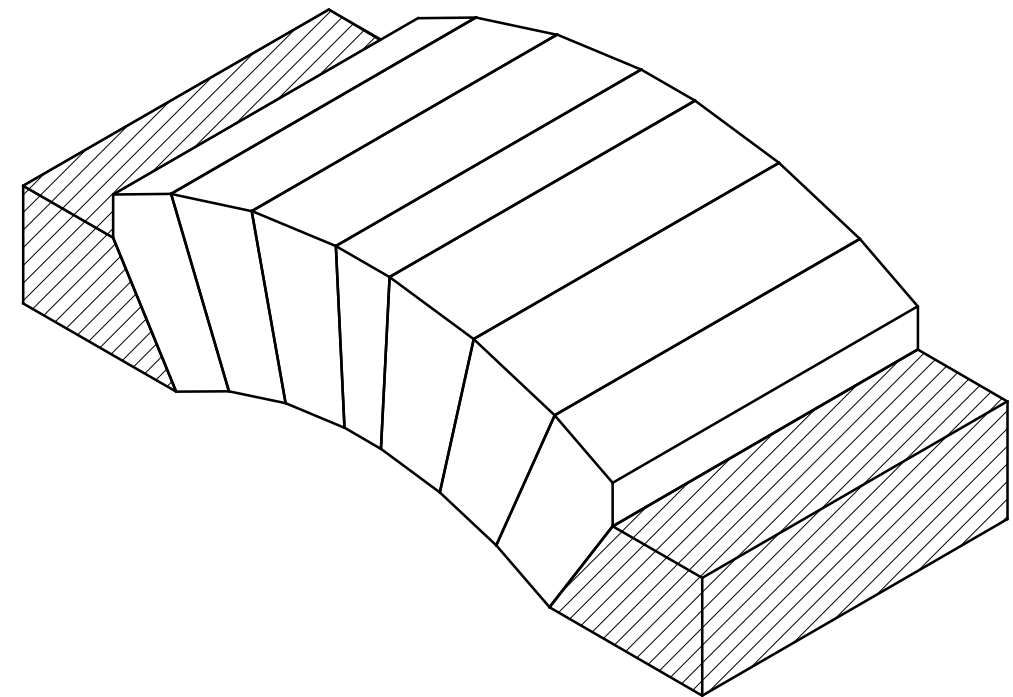

ALL BRICKS TO BE MORTARED IN PLACE

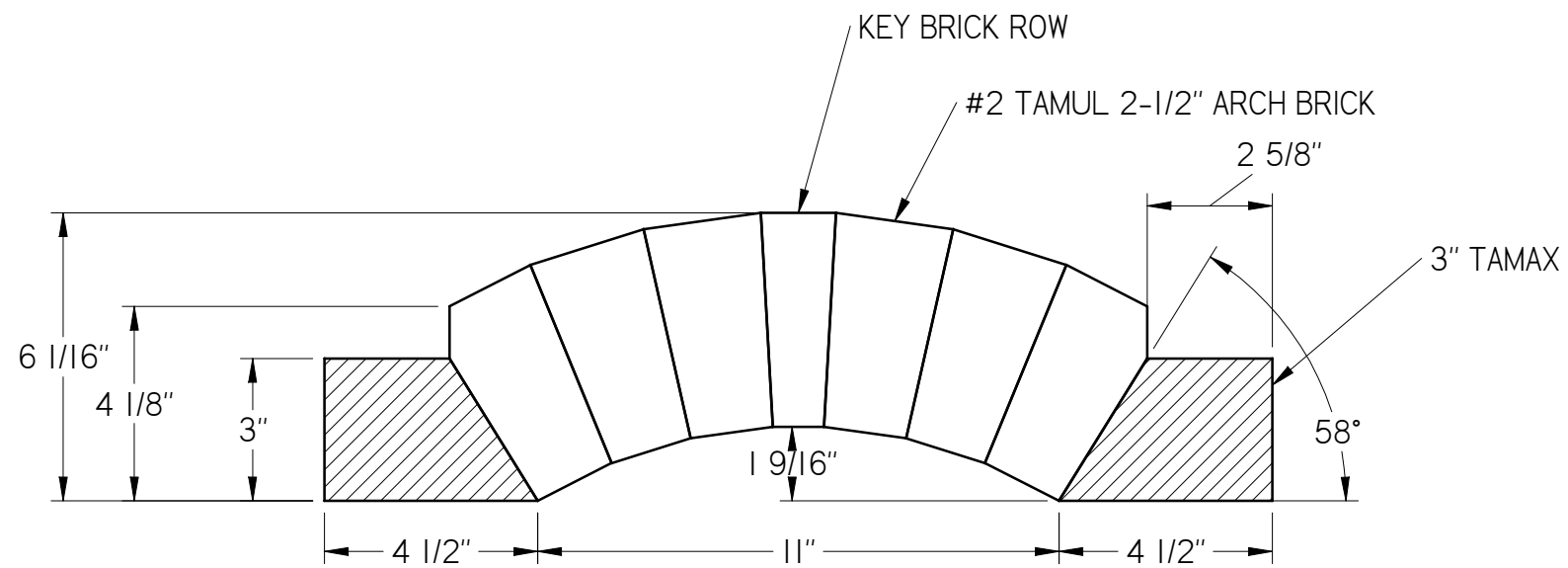

FRONT
1:4

THIS DOCUMENT IS FOR THE SOLE USE OF INDIVIDUALS AND IS NOT INTENDED TO BE COPIED OR DISTRIBUTED WITHOUT PERMISSION FROM SPIRAL ARTS, INC.

975 DAY TANK	SPIRAL ARTS		
	DOOR ARCH		
LICENSED TO: Public domain		Date 9/14/2005	
File: Tank core assembly.dft		Copyright Spiral Arts 2002	Drawn by Fred Metz

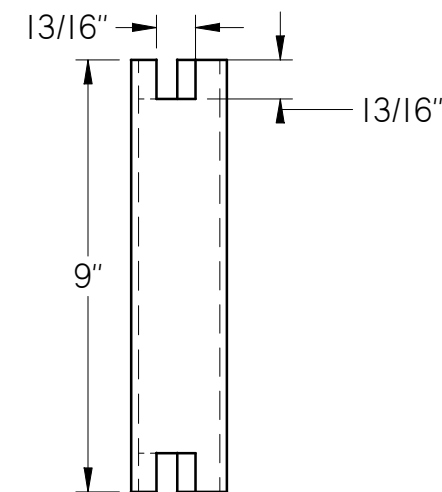
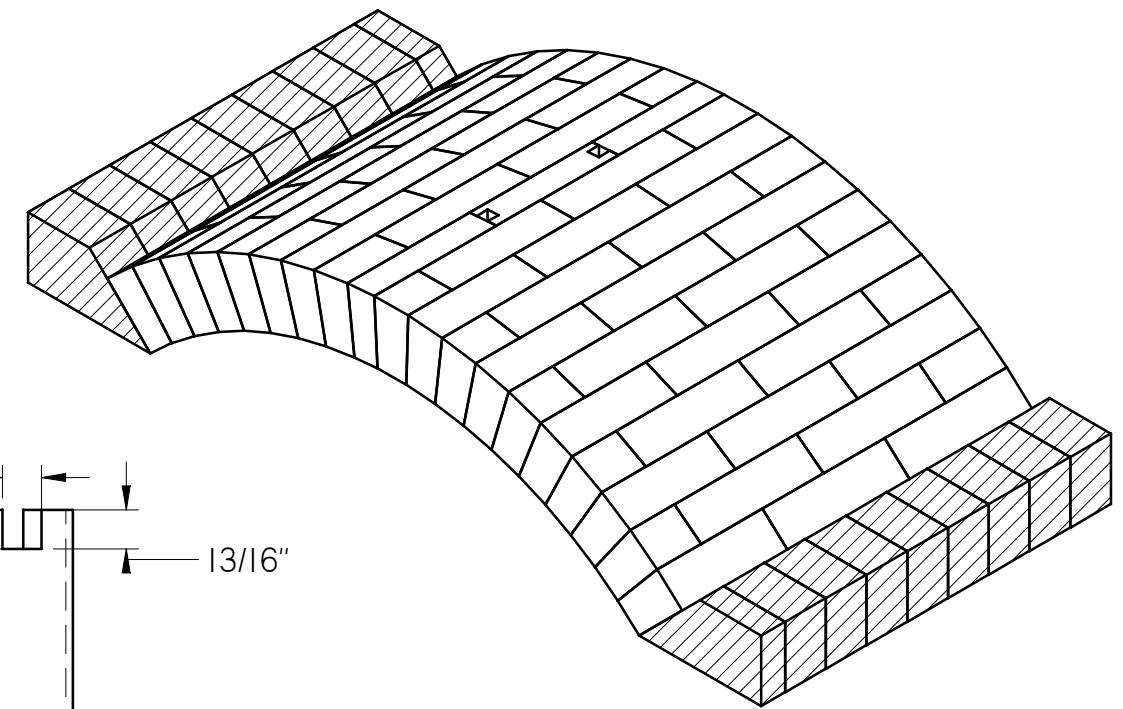
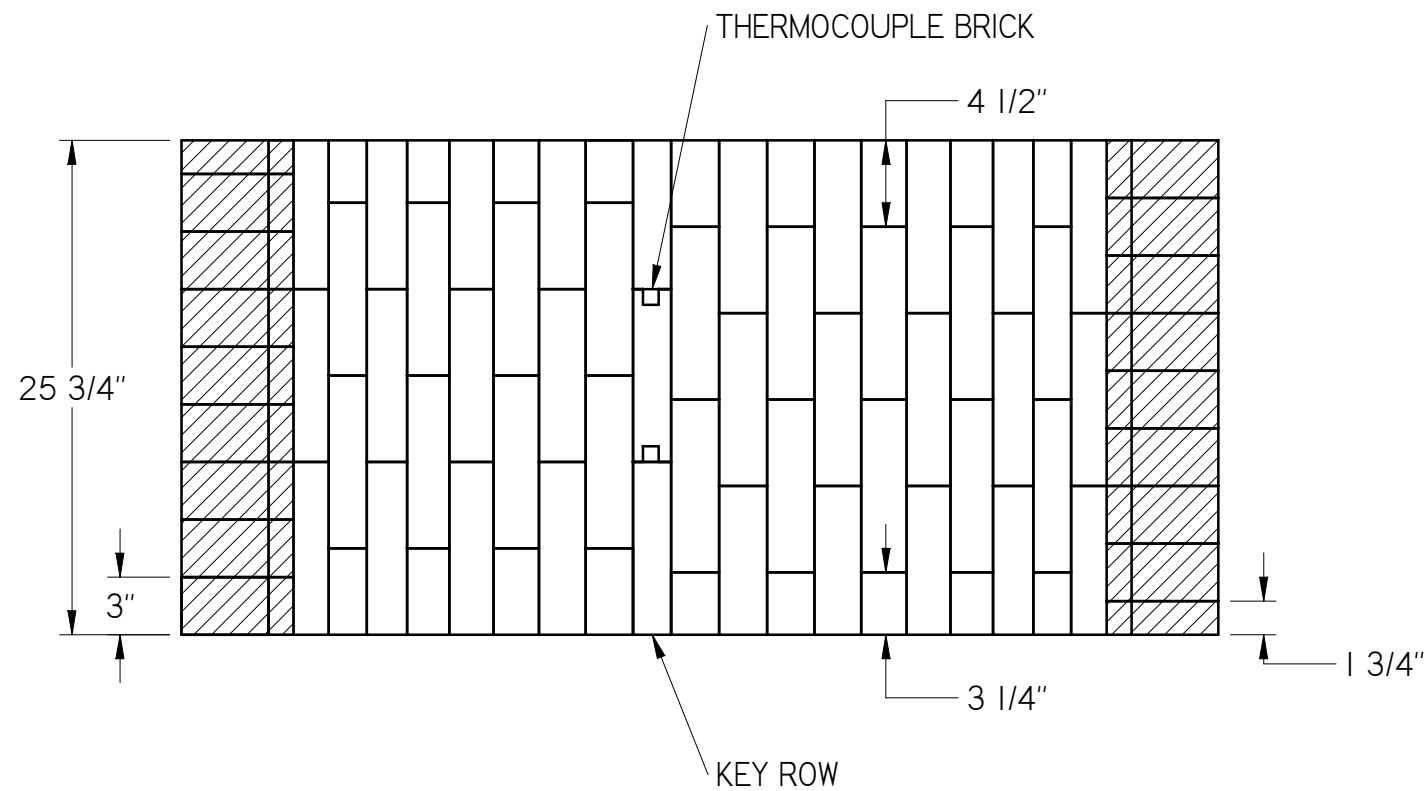

THERMOCOUPLE BRICK

ALL BRICKS TO BE MORTARED IN PLACE

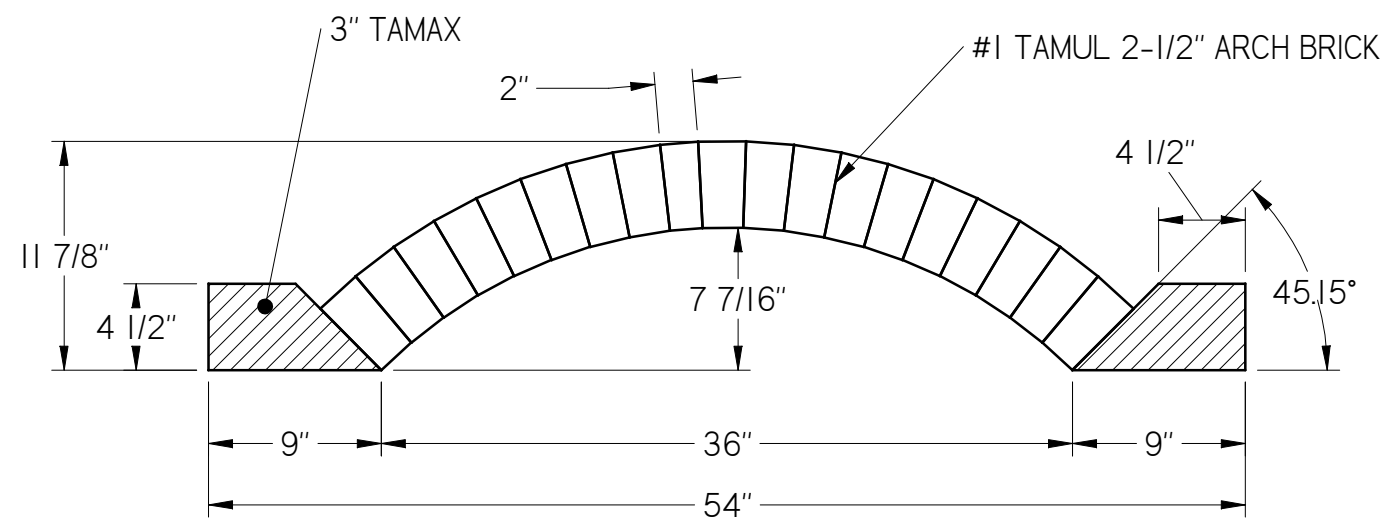

MAIN ARCH FRONT

THIS DOCUMENT IS FOR THE SOLE USE OF INDIVIDUALS AND IS NOT INTENDED TO BE COPIED OR DISTRIBUTED WITHOUT PERMISSION FROM SPIRAL ARTS, INC.

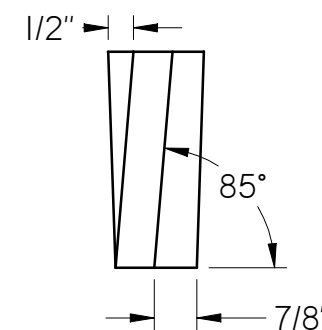

NOTE: THERMOCOUPLE BRICK / KEY BRICK DIMENSIONS ARE APPROXIMATE DIMENSIONS AND SHOULD BE CONFIRMED AND CUT JUST BEFORE PLACEMENT. DO NOT PRE CUT T/C BRICK. IF NECESSARY T/C HOLES MAY BE MOVED TO AN ADJACENT ROW.

975 DAY TANK	SPIRAL ARTS		
	MAIN ARCH		
LICENSED TO: Public domain		Date 9/14/2005	
File: Tank core assembly.dft	Copyright Spiral Arts 2002	Drawn by Fred Metz	

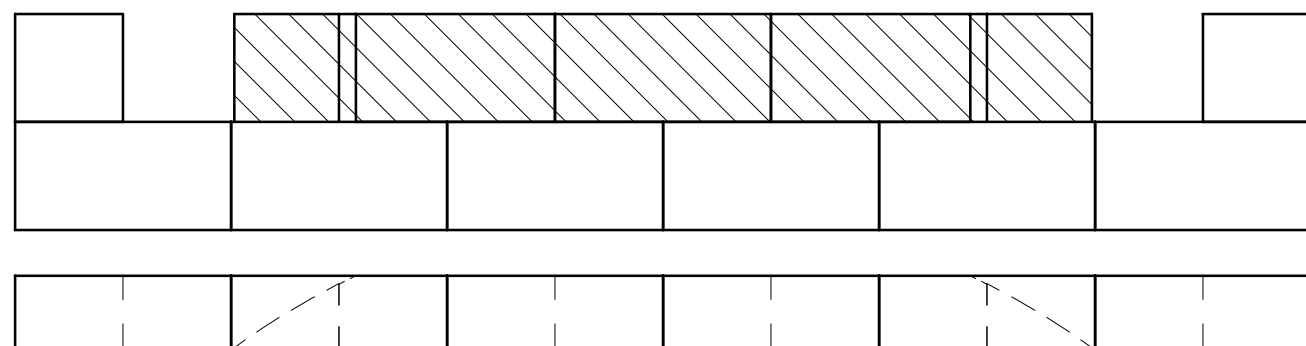

FRONT ROW 8

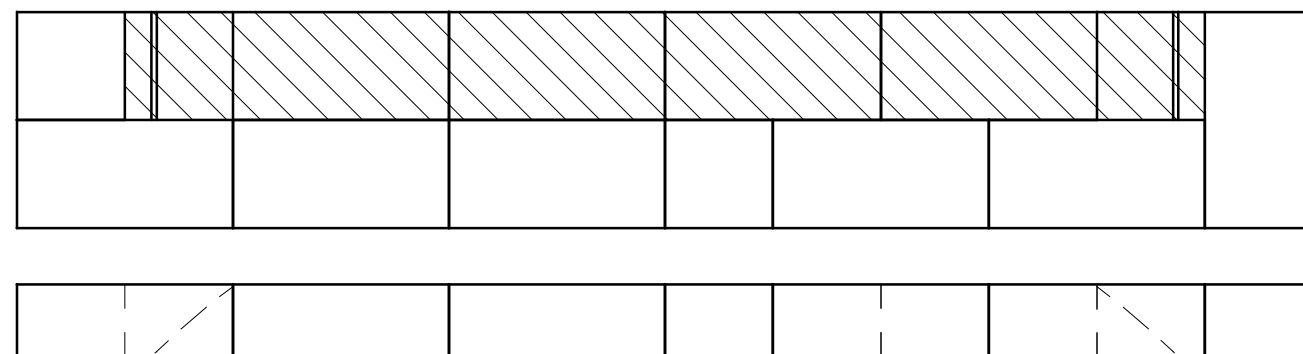

FRONT ROW 7

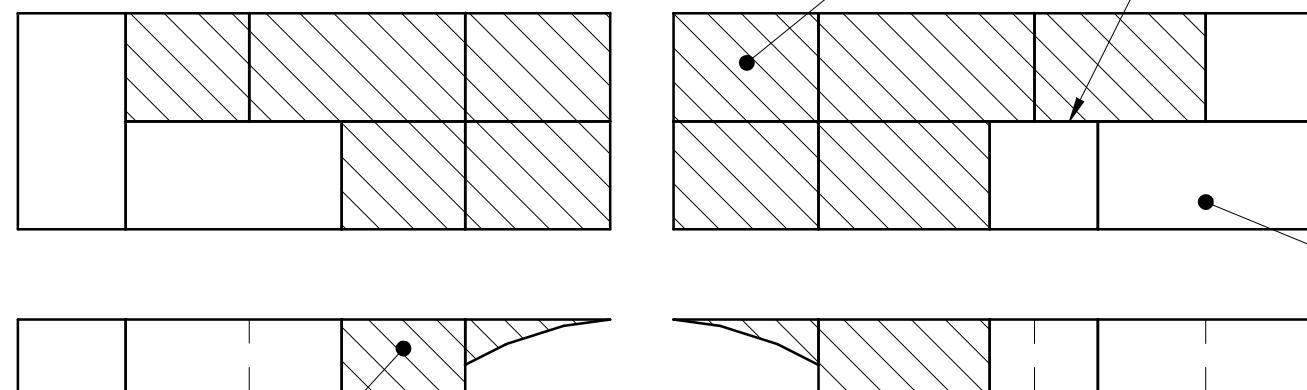

FRONT ROW 6

3" TAMAX

3" TAMAX

NO MORTAR BETWEEN IFB'S AND TAMAX

2600° IFB

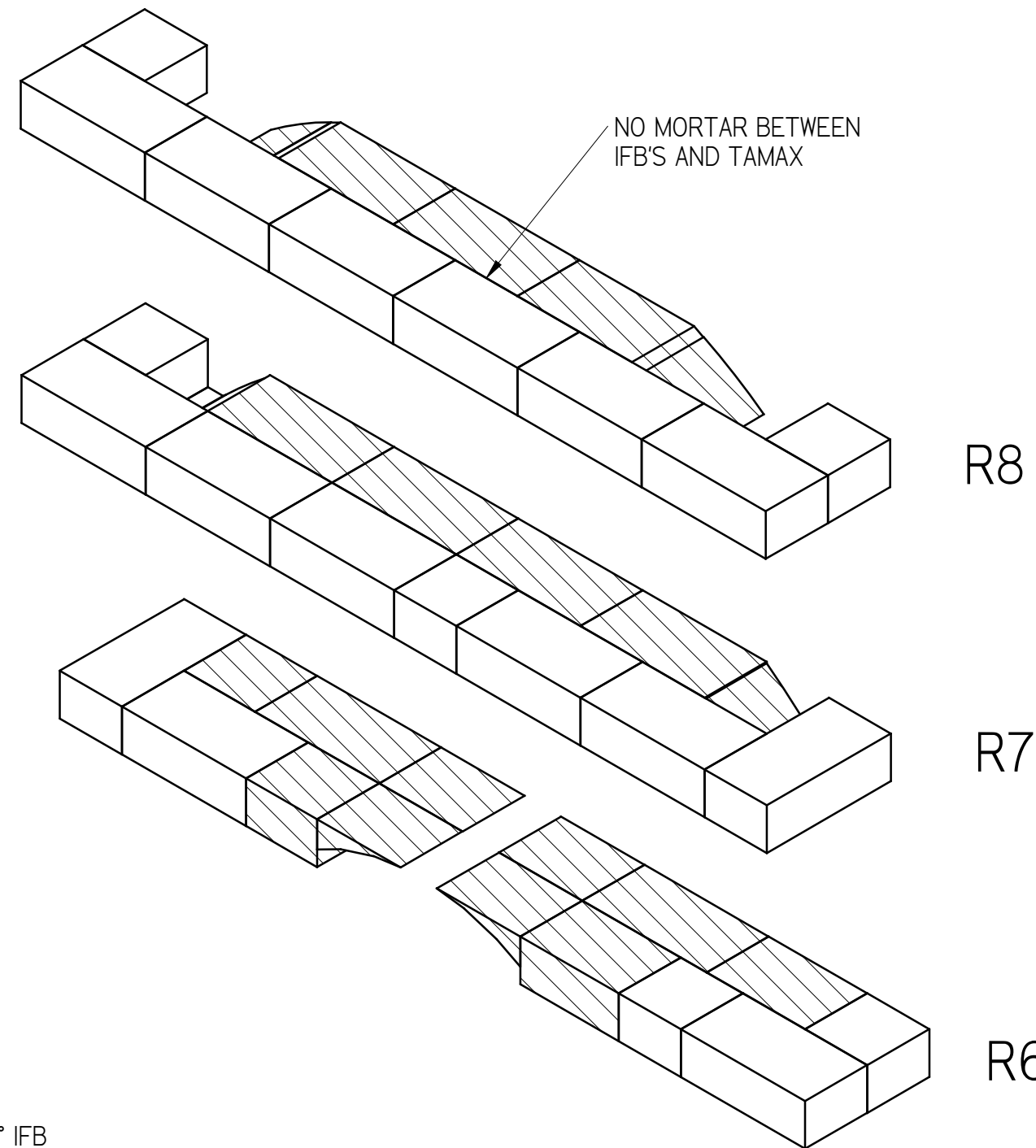

R8

R7

R6

NOTE: YOUR ACTUAL BRICK LAYOUT MAY VARY ABOVE ROW 5 DEPENDING ON THE ACTUAL HEIGHT OF YOUR ARCH. PLEASE LAY BRICKS TO MATCH ARCH NOT DRAWING.

THIS DOCUMENT IS FOR THE SOLE USE OF INDIVIDUALS AND IS NOT INTENDED TO BE COPIED OR DISTRIBUTED WITHOUT PERMISSION FROM SPIRAL ARTS, INC.

975 DAY TANK	SPIRAL ARTS		
	ROWS 6-8 OVER DOOR		
LICENSED TO: Public domain		Date 9/14/2005	
File: Tank core assembly.dft		Copyright Spiral Arts 2002	Drawn by Fred Metz

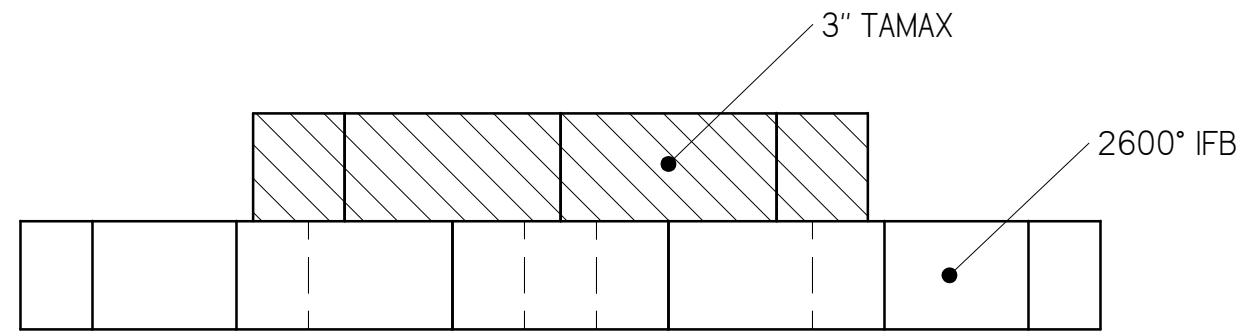

TOP VIEW

INSTALL THESE
TWO ROWS DRY
NO MORTAR

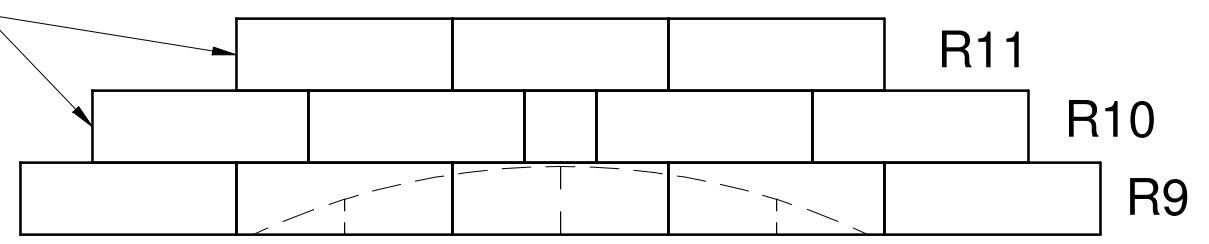

TOP 3 ROWS OF CROWN - FRONT

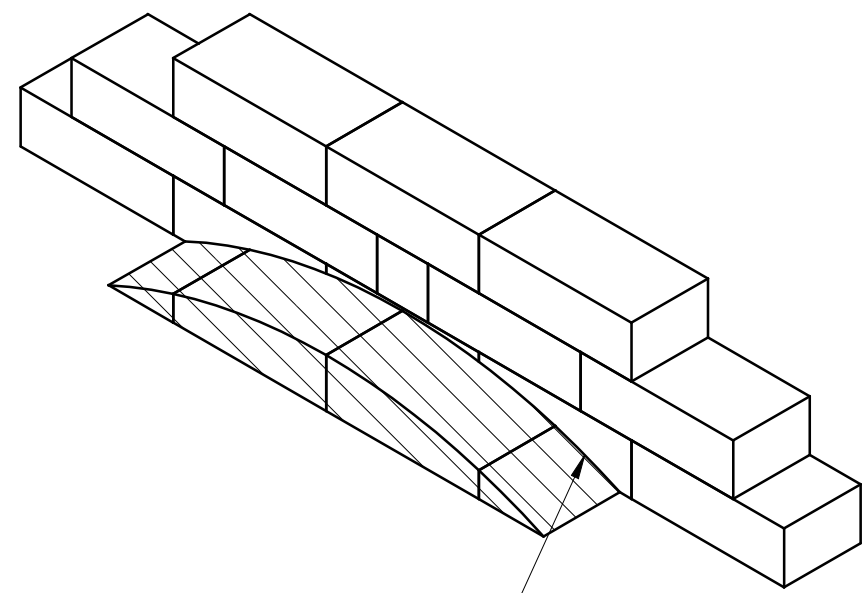

NO MORTAR BETWEEN
IFB'S AND TAMAX

THIS DOCUMENT IS FOR THE SOLE USE OF INDIVIDUALS
AND IS NOT INTENDED TO BE COPIED OR DISTRIBUTED
WITHOUT PERMISSION FROM SPIRAL ARTS, INC.

975 DAY TANK	SPIRAL ARTS		
	ROWS 9-11 OVER DOOR		
LICENSED TO: Public domain		Date 9/14/2005	
File: Tank core assembly.dft	Copyright Spiral Arts 2002	Drawn by Fred Metz	

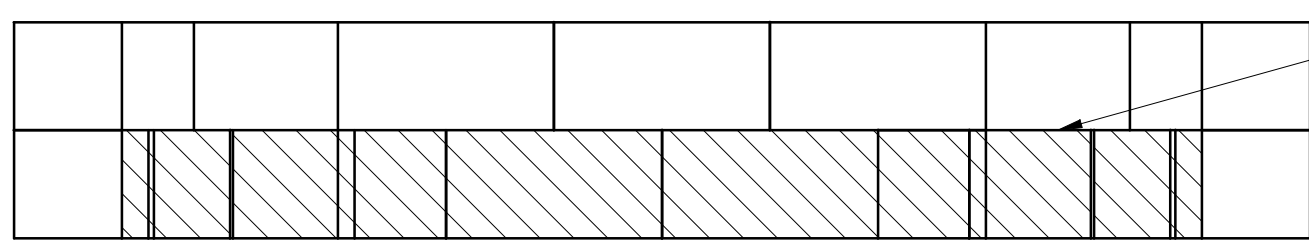

TOP

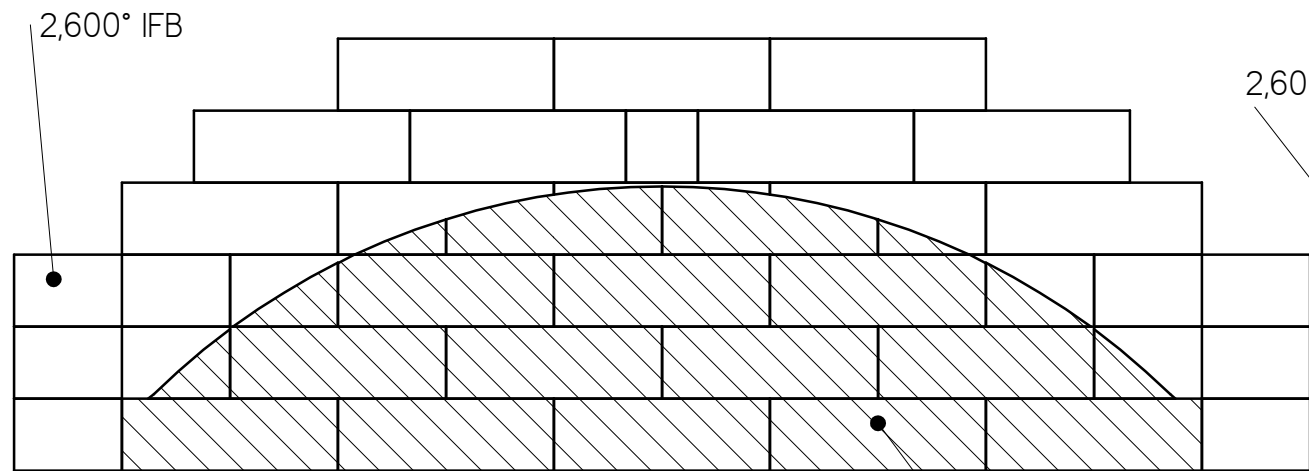

REAR WALL BEHIND ARCH

3" TAMAX

2,600° IFB

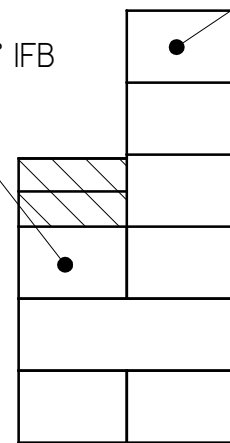

SIDE

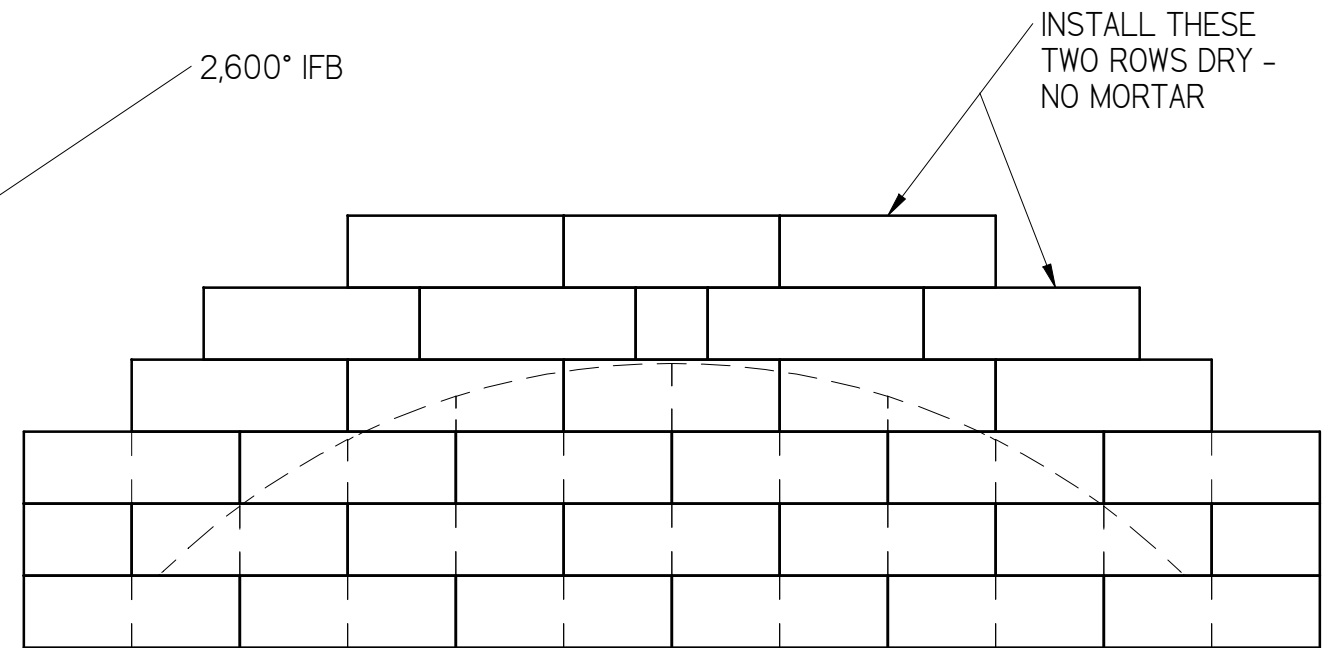

REAR WALL FROM BACK

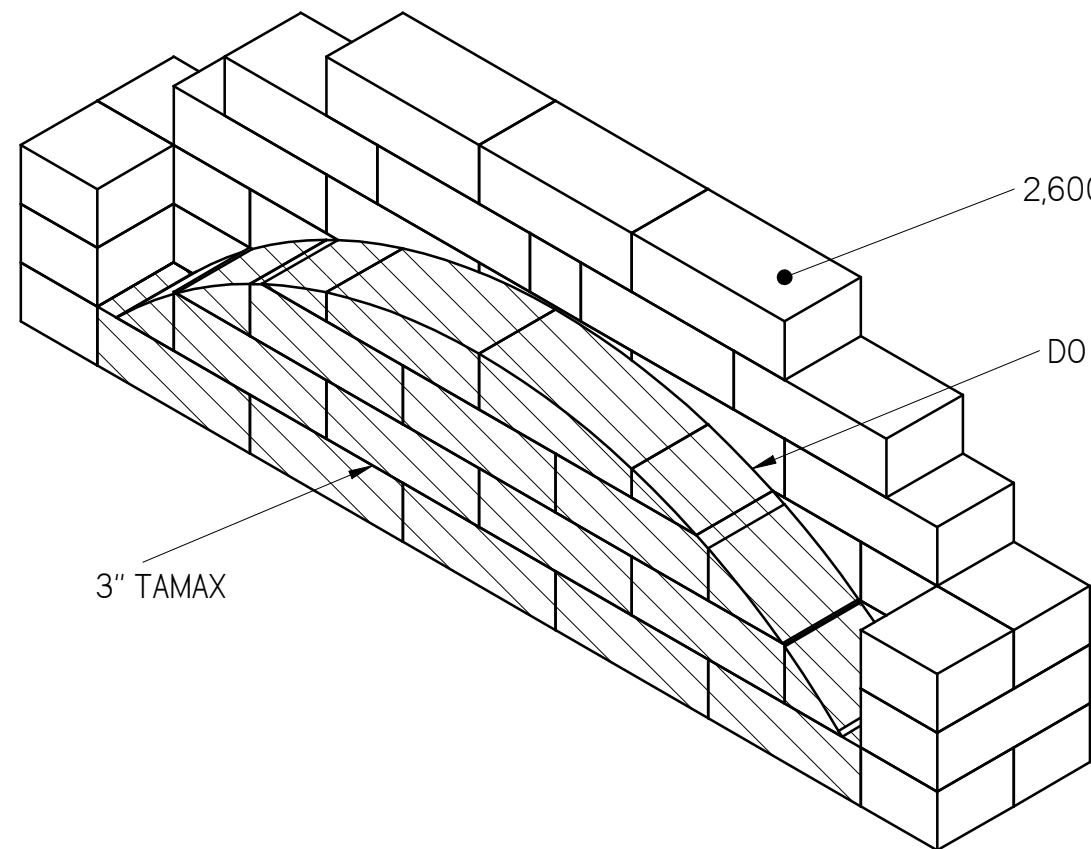

3" TAMAX

2,600° IFB

DO NOT MORTAR IFB'S TO TAMAX

THIS DOCUMENT IS FOR THE SOLE USE OF INDIVIDUALS AND IS NOT INTENDED TO BE COPIED OR DISTRIBUTED WITHOUT PERMISSION FROM SPIRAL ARTS, INC.

<p>975 DAY TANK</p>	<p><i>SPIRAL ARTS</i></p>		
	<p>ROWS 6-11 REAR ARCH</p>		
<p>LICENSED TO: Public domain</p>		<p>Date 9/14/2005</p>	
<p>File: Tank core assembly.dft</p>	<p>Copyright Spiral Arts 2002</p>	<p>Drawn by Fred Metz</p>	